

Document Title: <b>Steering system, component location</b>	Function Group: <b>600</b>	Information Type: <b>Service Information</b>	Date: <b>2014/6/3 0</b>
Profile: <b>WLO, L180F HL [GB]</b>			

## Steering system, component location

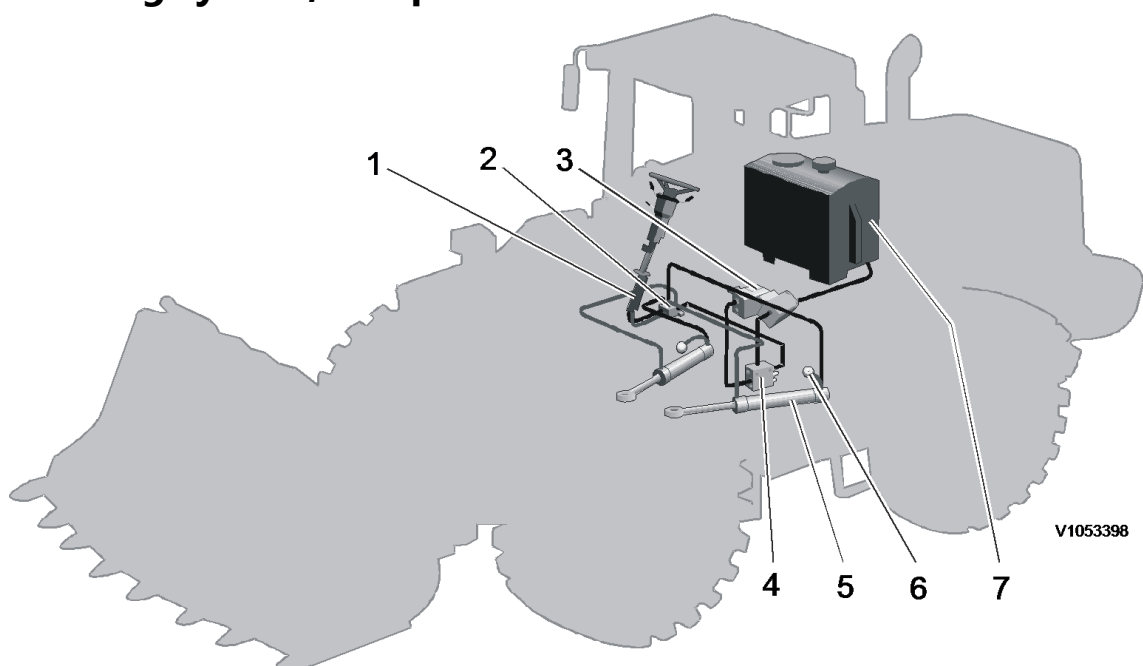

**Figure 1**  
**Steering system (principle illustration)**

1. Steering valve
2. Shift valve
3. Hydraulic pump
4. Central valve
5. Steering cylinder (2 pcs.)
6. Accumulator (2 pcs.)
7. Hydraulic tank

For description of the central valve, hydraulic pump and hydraulic tank, see [900 Hydraulic system and component positions](#).

### Steering valve

The steering valve is of the closed centre type. The steering valve is equipped with a load-sensing (LS) outlet from which a steering pressure is delivered to the LSS connection on the central valve. From the LS-connection on the central valve the steering pressure moves on to the flow compensator on P2.

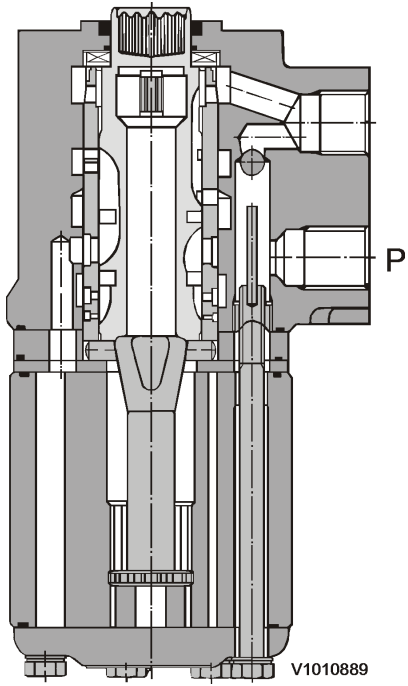

**Figure 2**  
**Steering valve**

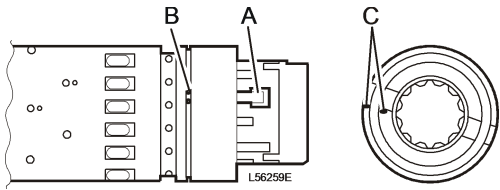

**Figure 3**

- A. T-shaped groove (inner spool)
- B. Hole (outer spool)
- C. Punch marks, must line up when installing

**Shift valve**

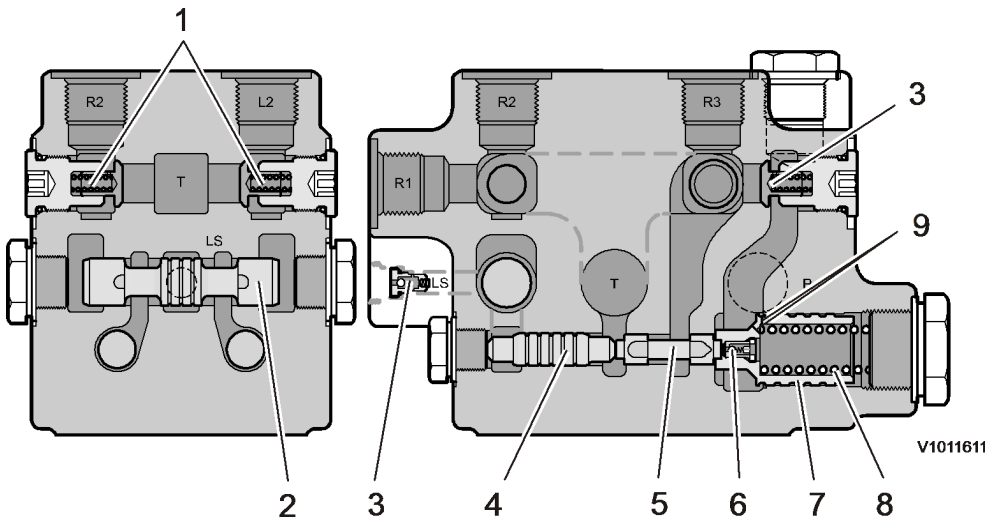
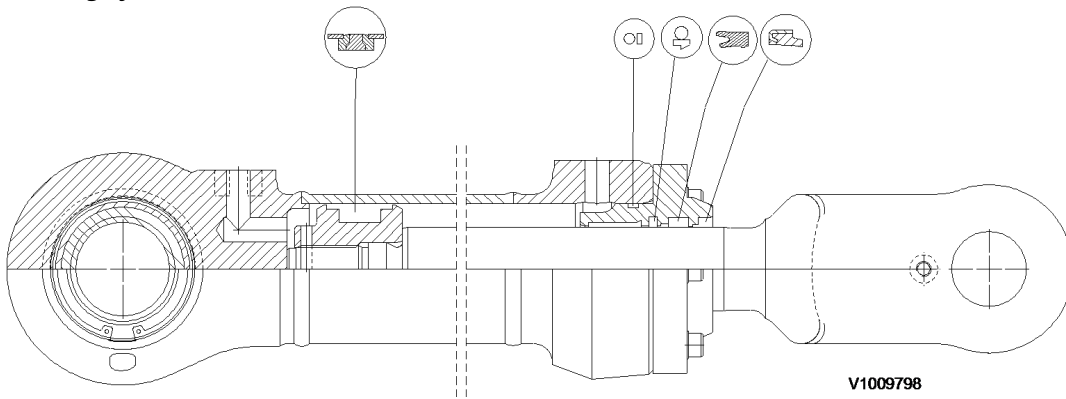

**Figure 4**

### Shift valve

1. Anti-cavitation valve
2. Directional spool
3. Non-return valve
4. Piston
5. Control spool
6. Non-return valve
7. Damping piston
8. Spring
9. Restriction

### Steering cylinder



**Figure 5**  
**Steering cylinder**

Document Title: <b>Steering description</b>	system, <b>600</b>	Function Group:	Information Type: <b>Service Information</b>	Date: <b>2014/6/3 0</b>
Profile: <b>WLO, L180F HL [GB]</b>				

## Steering system, description

The machine is provided with hydrostatic load-sensing (LS) articulated frame steering consisting of hydraulic pump P2, steering valve, shift valve, two accumulators and two steering cylinders. The pump is a variable axial piston pumps which is located on the transmission power take-off. P2 provides oil to the central valve, which gives priority to the steering system before the servo, brake and working hydraulic systems.

The purpose of the shift valve is to connect the minus side of the steering cylinder to increase the steering force during severe conditions. The minus side (piston rod end) of which cylinder is determined by the direction in which the machine is steered.

The purpose of the accumulators is to dampen pressure peaks against the steering cylinder piston, thus providing a smoother steering.

The steering valve is of the closed centre type. The steering valve is equipped with a load-sensing (LS) outlet from which a steering pressure is delivered to the LSS connection on the central valve. From the LSP-connection on the central valve the steering pressure moves on to the flow compensator on P2.

### Neutral position

P2 supplies oil to the priority spool in the central valve. Because the steering valve is closed and no LS-pressure is generated, the priority spool changes its position. As the priority spool is proportional, a stand-by pressure acts against the steering valve even though the priority spool has changed position over to working hydraulics.

Pressure builds up in the outlet line and the internal oil duct. When the steering is not used, the spring force of priority valve is overcome.

The spool closes the connection to the steering system and directs the oil over to the brake and servo systems and the working hydraulics.

The pump only supplies a stand-by pressure, as no steering is requested. Because the valve does not close fully, the pressure at the steering valve will be as great as the stand-by pressure.

The P1 connection is connected to the pump and the P2 connection to the steering valve. The steering valve is in neutral position, and therefore only stand-by pressure is built up in the shift valve up to the control spools and also in the damping pistons, via the non-return valves and the restrictions. The minus sides (piston rod ends) of the steering cylinders are connected to tank through the control spools. The oil at the plus sides (piston ends) of the respective steering cylinders is closed in by the steering valve. The same enclosed oil actuates the directional spool. The oil in the LS-duct is also enclosed because of the non-return valve.

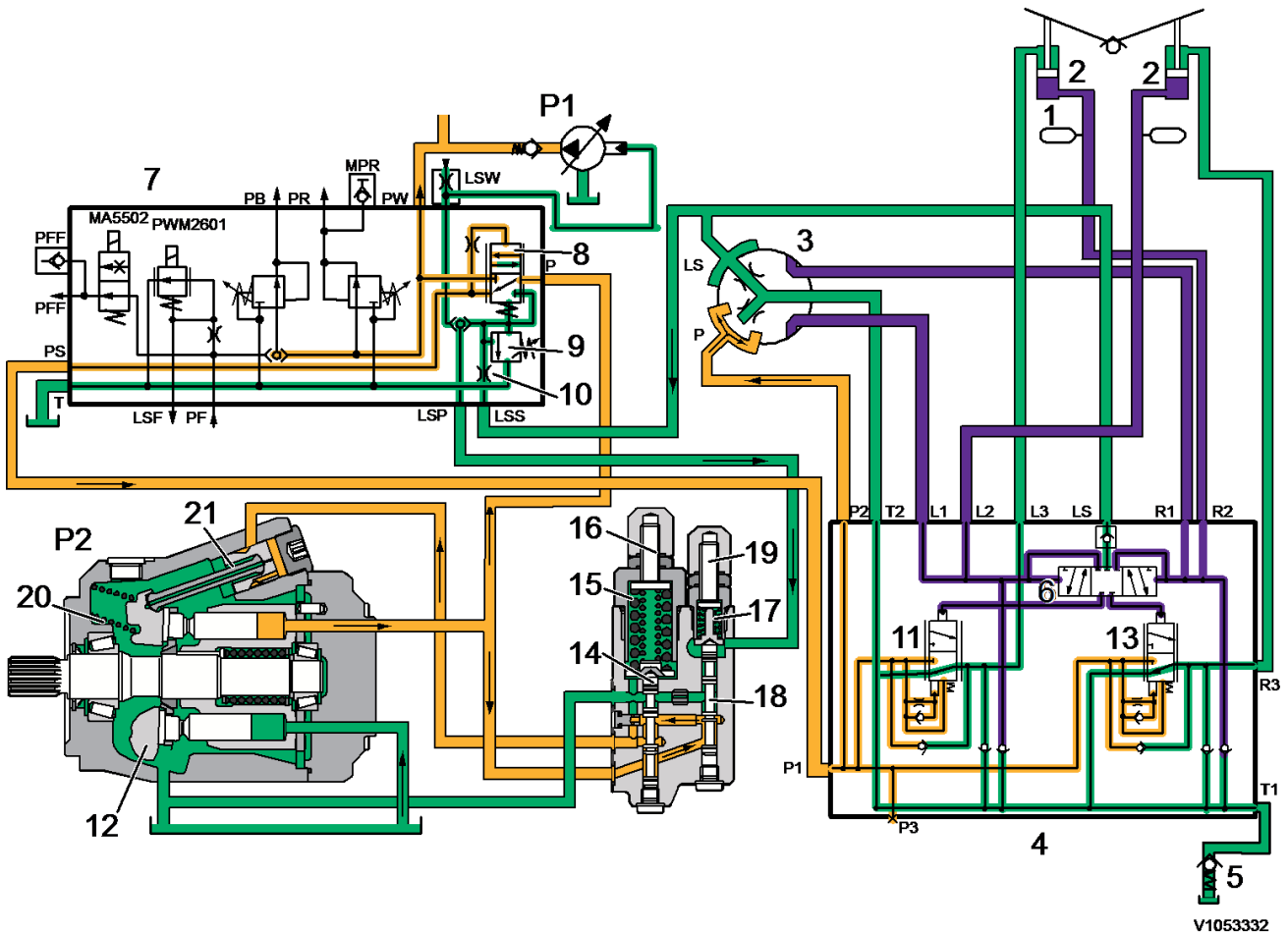

**Figure 1**  
**Neutral position**

Green	Return, without pressure
Violet	Oil closed in
Orange	Stand-by pressure

1. Accumulators
2. Steering cylinders
3. Steering valve
4. Shift valve
5. Pressure back-up valve, counteracts cavitation
6. Directional spool
7. Central valve
8. Priority valve
9. Pressure-limiting valve for max. steering pressure
10. Restriction
11. Control spool
12. Yoke, pump
13. Control spool
14. Pressure compensator spool
15. Spring
16. Adjusting screw, maximum pressure working hydraulics
17. Spring
18. Flow compensator spool
19. Adjusting screw, stand-by pressure
20. Spring
21. Control piston

### Steering, right (favourable conditions)

The steering valve is turned and steering pressure passes on out to one of the steering cylinders via the shift valve. The LS-line becomes connected to one of the outlet ports on the steering valve. The LS-pressure enters on the underside of the priority valve and forces, together with the spring force, the spool up and opens the connection to the steering valve.

Thereby the steering is prioritised above the brake and servo systems and the working hydraulics. The LS-pressure then passes on to the top of the flow compensator spool and together with the spring force the spool is forced into a balanced position against the pressure in the duct. The oil behind the control piston can now be drained via the spools and back to the pump housing and the yoke is angled towards maximum flow with the aid of the spring.

The pump supplies an amount of oil that is proportional to steering lock and steering speed. When the pump supplies the correct flow, the valve is balanced by the pressure in the LS-line plus the spring against the pressure in the duct.

Oil from the steering valve enters at connection R1, flows on to the plus side (piston end) of the left steering cylinder from connection R2 and actuates the directional spool. The directional spool changes over so that oil from the LS-line reaches the piston in the directional spool. The LS-pressure is too low to displace the control spool. The plus side (piston rod end) of the right steering cylinder is filled with oil from the return side via the control spool and one of the anti-cavitation valves. The machine is only steered with oil to the plus side (piston end) of the left steering cylinder. Afterfilling takes place because of the pressure back-up valve. When steering left, the sequence of events is opposite of the above.

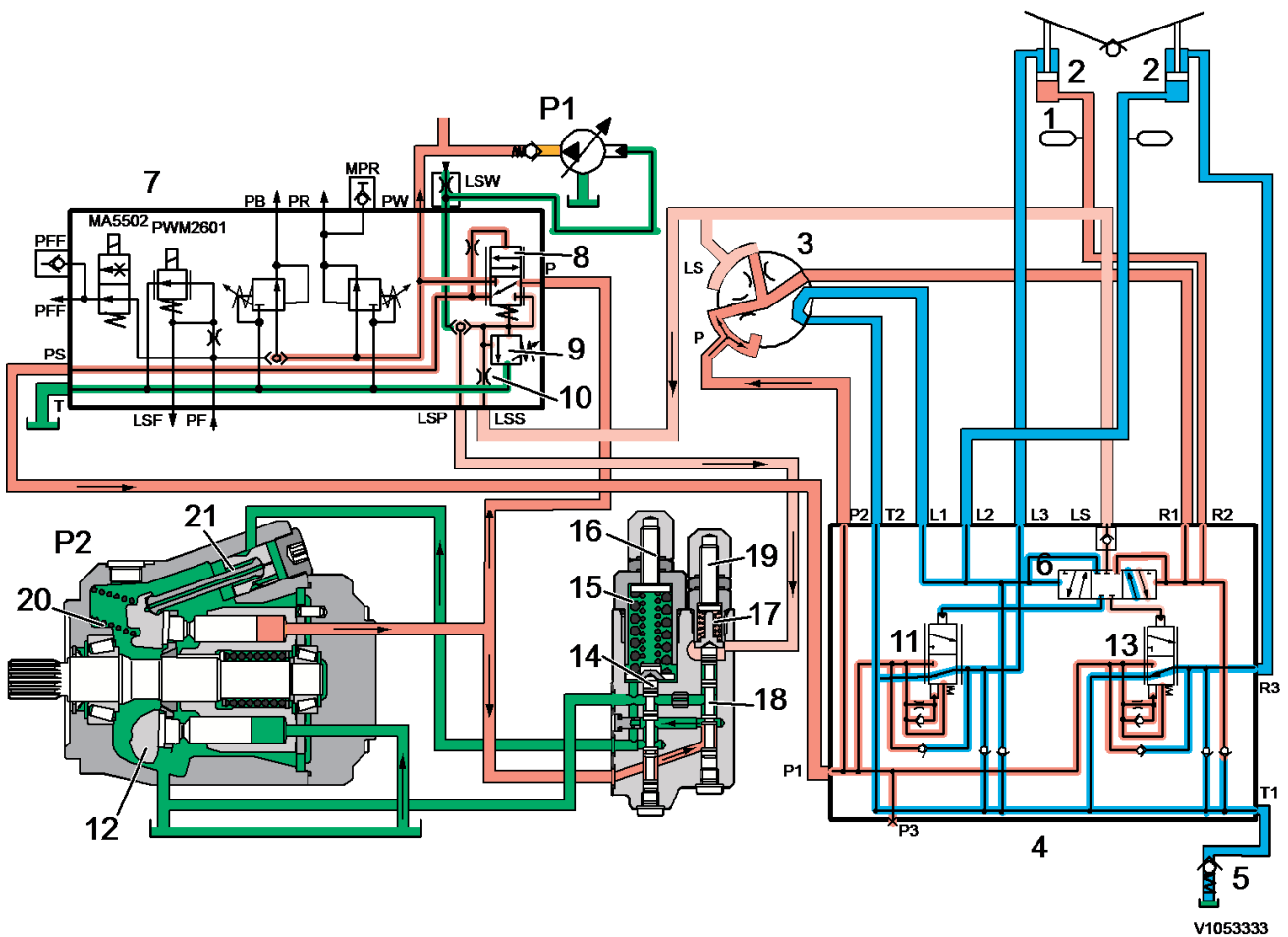

**Figure 2**  
**Steering, right (favourable conditions)**

Red 2	Working pressure, low
Pink	LS-pressure
Green	Return, without pressure
Orange	Stand-by pressure
Blue	Raised return pressure

1. Accumulators
2. Steering cylinders
3. Steering valve
4. Shift valve
5. Pressure back-up valve, counteracts cavitation
6. Directional spool
7. Central valve
8. Priority valve
9. Pressure-limiting valve for max. steering pressure
10. Restriction
11. Control spool
12. Yoke, pump
13. Control spool
14. Pressure compensator spool
15. Spring
16. Adjusting screw, maximum pressure working hydraulics
17. Spring
18. Flow compensator spool
19. Adjusting screw, stand-by pressure
20. Spring
21. Control piston

### **Steering, right (severe conditions)**

When the pressure in the LS-line rises to max. steering pressure, the pressure-limiting valve opens to tank. The LS-pressure drops after the restriction when a flow is obtained across the restriction.

The valve in the pressure compensator is kept in the lower position by the spring. The spring balances the flow compensator valve so that oil reaches the control piston. The pressure from the pump is regulated to a value dependent on the force of the spring plus the pressure in the LS-line after the restriction.

The pump pressure is the same as the max. steering pressure and is adjusted with the aid of the pressure-limiting valve. The angle of the yoke is reduced and thereby the flow, but max. steering pressure is maintained.

The initial position is identical to steering under light conditions. The LS-pressure actuates the control spool in the shift valve. Before the control spool opens, the restriction closes and the oil can only be drained through the restriction and this provides a smooth pressure-build-up out to the minus side of the right steering cylinder. The non-return valve ensures engagement even if the LS-pressure drops momentarily. The machine is steered with oil to the plus side (piston end) of the left steering cylinder and the minus side (piston rod end) of the right steering cylinder.

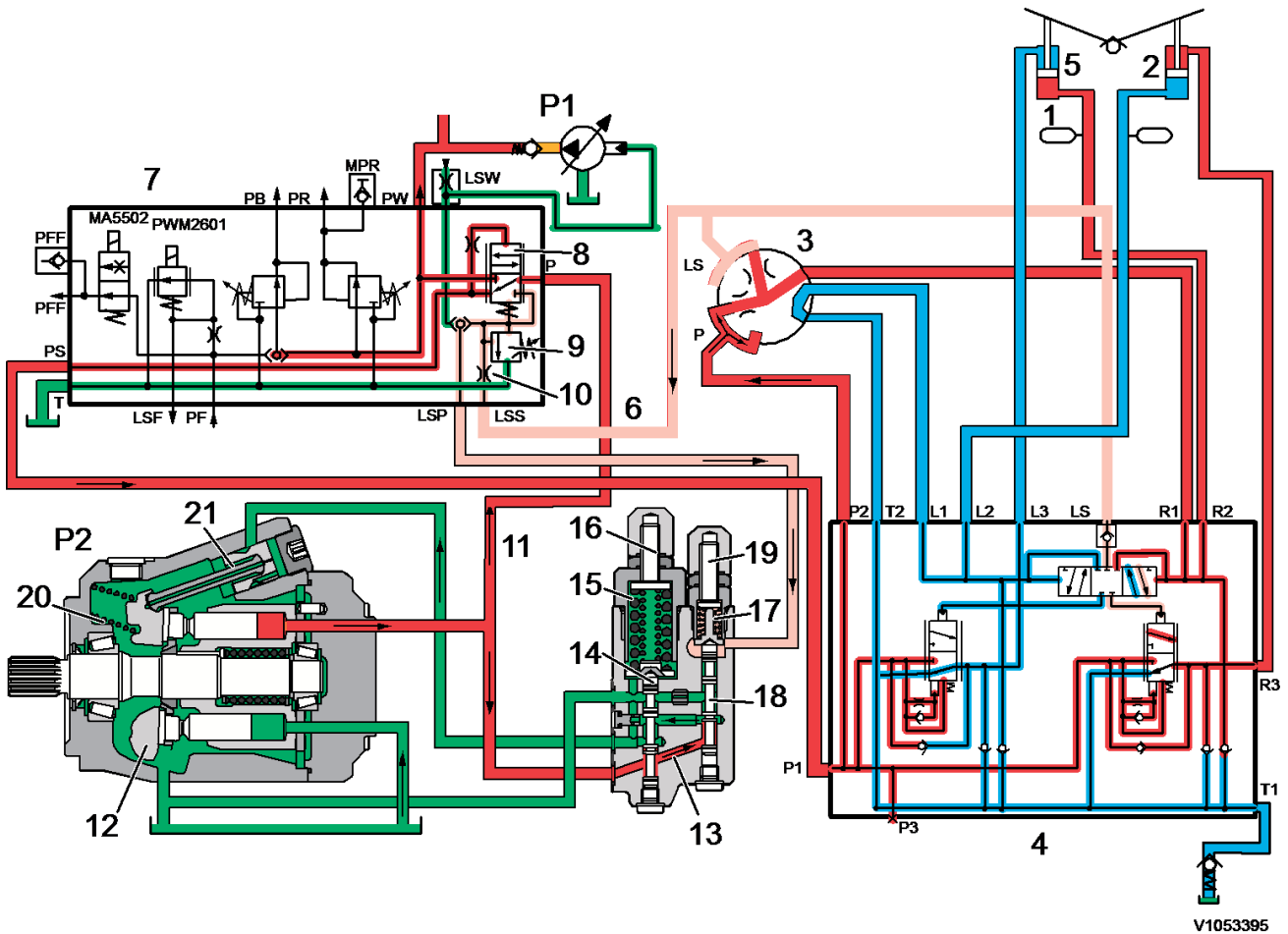

**Figure 3**  
**Steering, right (severe conditions)**

Blue	Raised return pressure
Green	Return, without pressure
Orange	Stand-by pressure
Red	Working pressure
Red 2	Working pressure, low
Pink	LS-pressure

1. Accumulators
2. Steering cylinders
3. Steering valve
4. Shift valve
5. Pressure back-up valve, counteracts cavitation
6. Directional spool
7. Central valve
8. Priority valve
9. Pressure-limiting valve for max. steering pressure
10. Restriction
11. Control spool
12. Yoke, pump
13. Control spool
14. Pressure compensator spool
15. Spring
16. Adjusting screw, maximum pressure working hydraulics
17. Spring
18. Flow compensator spool



19. Adjusting screw, stand-by pressure
20. Spring
21. Control piston

Document Title: <b>Steering system, function check</b>	Function Group: <b>600</b>	Information Type: <b>Service Information</b>	Date: <b>2014/6/3 0</b>
Profile: <b>WLO, L180F HL [GB]</b>			

## **Steering system, function check**

### **Op nbr 600-001**

1. Start the engine. Check that the steering operates smoothly and is responsive, and that the steering lock is in proportion to the steering wheel movement.
2. Leave the engine running at the speed given in the specifications. Check the steering time by turning the steering wheel in order to achieve maximum steering speed. Steering time and speed, see [645 Steering, specifications](#).

Document Title: <b>Steering system, checking and adjusting working pressure</b>	Function Group: <b>645</b>	Information Type: <b>Service Information</b>	Date: <b>2014/6/3 0</b>
Profile: <b>WLO, L180F HL [GB]</b>			

## Steering system, checking and adjusting working pressure

Op nbr 645-028

[14290266 Hose](#)

[11666051 Pressure gauge](#)

1. Warm up the machine until the hydraulic system is at operating temperature, 60–80 °C (140–176 °F).
2. Secure the frame joint with the frame joint lock. Place blocks in front of and behind the wheels.

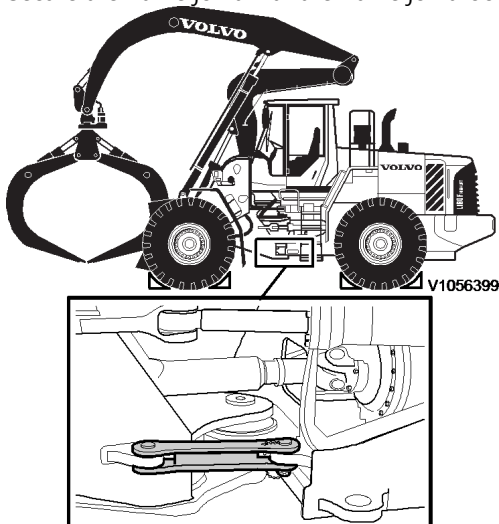

**Figure 1**

3. Connect the pressure gauge to the checking point on the steering valve.

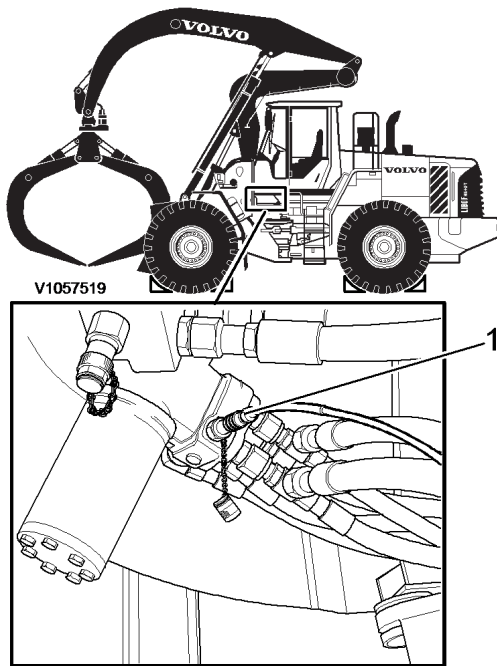

**Figure 2**

1. Checking point

### Checking stand-by pressure

4. Start the engine and run at low idling speed. Read off the stand-by pressure.

Stand-by pressure, see [030 Hydraulic pump \(P2\), specifications](#).

**NOTE!**

The steering system stand-by pressure is determined by the stand-by pressure of pump and by the opening pressure of the priority spool. The stand-by pressure for steering cannot be adjusted separately, instead the pressure is adjusted on the flow compensator on pump P2, see [913 Hydraulic pump, checking and adjusting standby pressure](#). If the stand-by pressure is correct at the pump, but not for the steering, this may be because of a fault in the priority spool of the central valve.

### Checking steering pressure

5. Steer against the frame joint lock in both directions and check the steering pressure at the respective end position.  
Steering pressure, see [030 Steering, specifications](#).
6. Stop the engine.

### Adjusting steering pressure

7. **NOTE!**

The engine must be turned off when the steering pressure is adjusted.

Adjust the steering pressure on the pressure-limiting valve on the central valve.

Steering pressure, see [030 Steering, specifications](#).

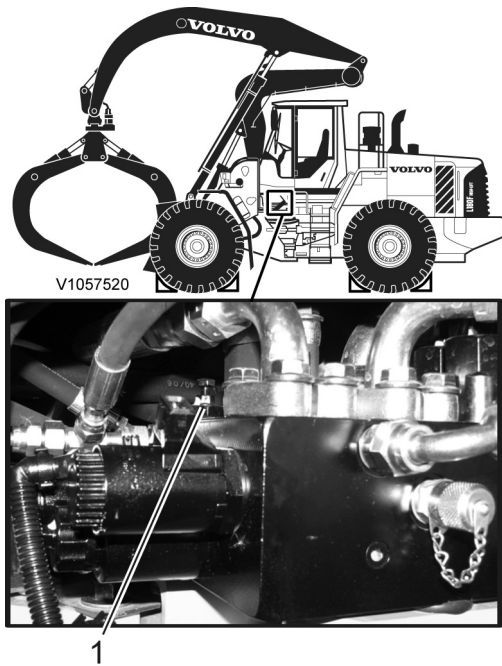

**Figure 3**

1. Pressure-limiting valve, steering pressure
8. Turn off the engine and remove the pressure gauge.
9. Restore the machine.
10. Test the function of the steering system according to [600 Steering system, function check](#).

**Thank you very much for reading.**

**This is part of the demo page.**

**GET MORE:**

**Hydraulic**

**System, Setting**

**Instructions, Functional**

**Description, Electrical**

**System And more.....**

**Click Here [BUY NOW](#)**

**Then Instant Download**

**the Complete Manual.**