

Document Title: <b>Description</b>	Function Group: <b>700</b>	Information Type: <b>Service Information</b>	Date: <b>2014/6/6 0</b>
Profile:			

## Description

The front frame is made up as an open box section.

It supports the loader unit and carries the front axle.

The rear frame consists of two frame members which are of a closed box design.

The rear frame carries the cab, engine and transmission.

The rear axle and the counterweight are also attached to the rear frame.

Engine and transmission are mounted in the frame on rubber cushions.

Important contact surfaces between the frame and components are machined, thus an accurate fit and strong joints are obtained.

The frame joint is dimensioned to cope with great stresses.

The upper bearing consists of a spherical linkage bearing and the lower bearing consists of two taper roller bearings.

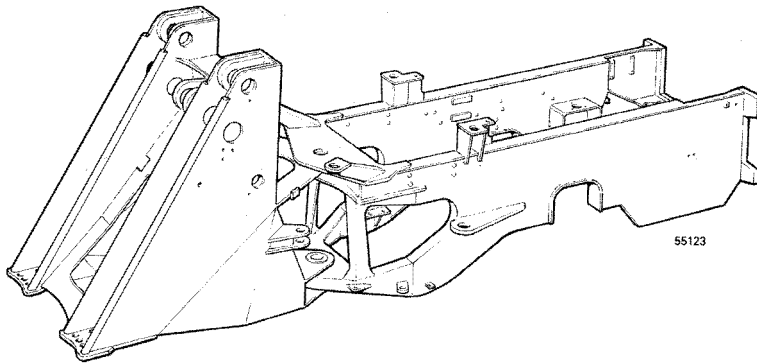

**Figure 1**  
**Frame**

Document Title: <b>Tightening torques</b>	Function Group: <b>700</b>	Information Type: <b>Service Information</b>	Date: <b>2014/6/6 0</b>
Profile:			

## Tightening torques

**Important! Bolted joints which are not listed here should be tightened according to table on page 0:5**

### Frame joint

	<b>L150/L180</b>
	<b>N m(lbf ft)</b>
Bearing housing – frame, lower	85 (63)
Bearing cover – shaft stud, upper	220 (162)
Bearing cover – frame	220 (162)
Bearing cover – shaft stud, lower	220 (162)

Document Title: <b>Frame joint, changing bearings and pins</b>	Function Group: <b>741</b>	Information Type: <b>Service Information</b>	Date: <b>2014/6/6 0</b>
Profile:			

## Frame joint, changing bearings and pins

### Op nbr 71436

[999 3651 Draw bolt M30 length 650mm \(25.6in\)](#)

[999 3713 Draw bolt M20 length 700mm \(27.6in\)](#)

[999 3715 Intermediate piece](#)

[999 3722 Support](#)

[999 3725 Draw bolt M20 length 160mm \(6.3in\)](#)

[999 3739 Support](#)

[999 3742 Socket](#)

[E 985 Hose](#)

[11 666 013 Pump](#)

[11 666 014 Jack 12tonnes](#)

[11 666 015 Jack 30tonnes](#)

[11 667 001 Handle](#)

[11 667 100 Drift plate](#)

[11 667 110 Drift plate](#)

[11 667 120 Drift plate](#)

[11 667 130 Drift plate](#)

[11 667 170 Drift plate](#)

[11 667 171 Drift plate](#)

[Ratchet block 750kg \(1654lb\), 2 pcs](#)

[Bottle-type jack 1.5tonnes, 3 pcs](#)

[Screw stud M16 x 260mm \(10.2in\), 2 pcs](#)

### **NOTE!**

The fitting of the pivot pins is facilitated if the pins are cooled down in a freezer to approx. -25°C (-13°F) before they are fitted.

### **Parting machine**

1. Lower the lifting frame and release the hydraulic oil pressure.

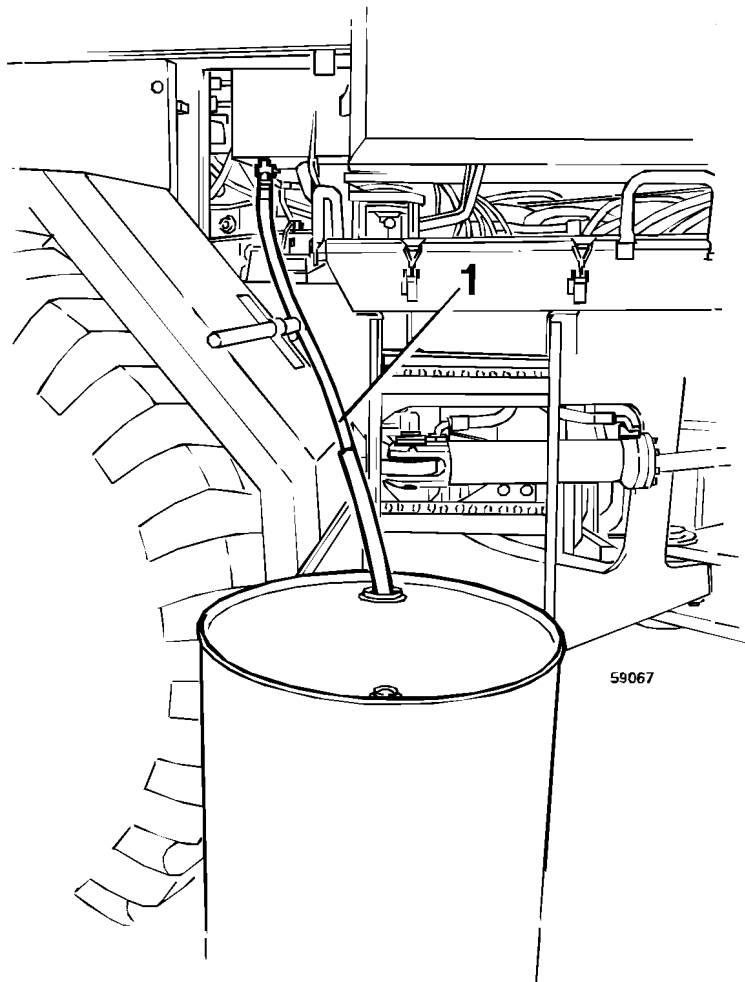

**Figure 1**  
**Draining hydraulic oil**

1	E 985
---	-------

2. Release the pressure in the brake system by depressing the brake pedal repeatedly (30 – 40 times).
3. Turn off the battery disconnect switch.
4. Drain the hydraulic oil, see [Figure 1](#).
5. Remove the front propeller shaft, see [Figure 2](#).  
Weight approx. 30kg (66lb).  
Lift one of the front wheels and rotate the propeller shaft half a turn in order to gain access to all bolts.

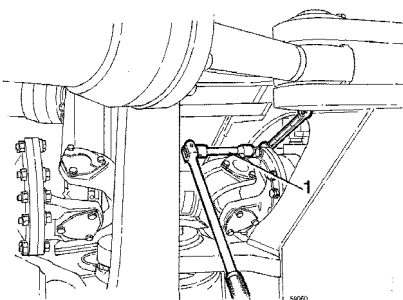

**Figure 2**  
**Removing propeller shaft**

1	3742
---	------

- Remove the wall lining over the electrical distribution box and detach connector F and when applicable also connector FE in the electrical distribution box and the earth connection. Loosen the clamps and detach the cable harness from the rear frame.

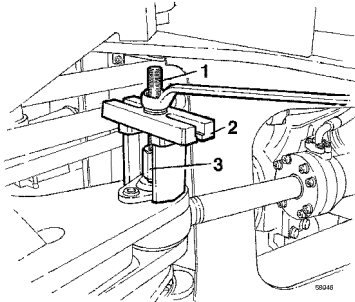

**Figure 3**  
**Removing piston rod, steering cylinder**

1	3725
2	3722
3	3715

- Detach the steering cylinder piston rods, see [Figure 3](#).
- Detach pressure hose and return hose from the couplings at the frame joint. Position an oil vessel under, in order to collect the oil which runs out of the hoses.

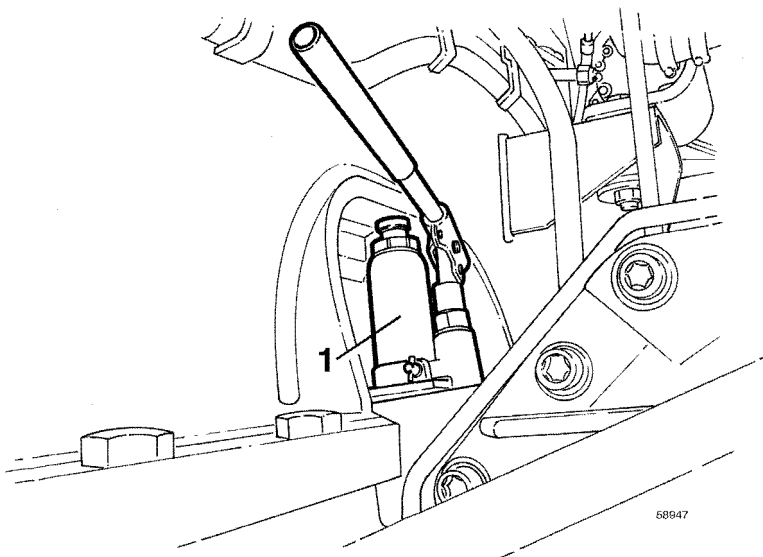

**Figure 4**  
**Blocking rear axle oscillation**

1	Bottle-type jack, 1.5tonnes
---	-----------------------------

- Block the rear axle oscillation by positioning a jack on either side of the machine between frame and rear axle, see [Figure 4](#).
- Loosen the steering system shift valve and the clamping at the upper frame joint pin. Move aside and if necessary tie up servo hoses and brake hose so that the upper frame joint pin can be extracted.
- Position two jacks under the rear part of the machine, one under the guard plate and one under the transmission.

Position an axle stand under the front frame in front of the frame joint, see [Figure 5](#).

**NOTE!**

The front frame is front-heavy by a weight of approx. 1600kg (3528lb) (when a standard bucket is fitted), thus varying with the size of the bucket. Without a bucket, the weight of the front frame at the frame joint is approx. 500kg (1103lb).

The rear frame is rear-heavy by a weight of approx. 1950kg (4300lb).

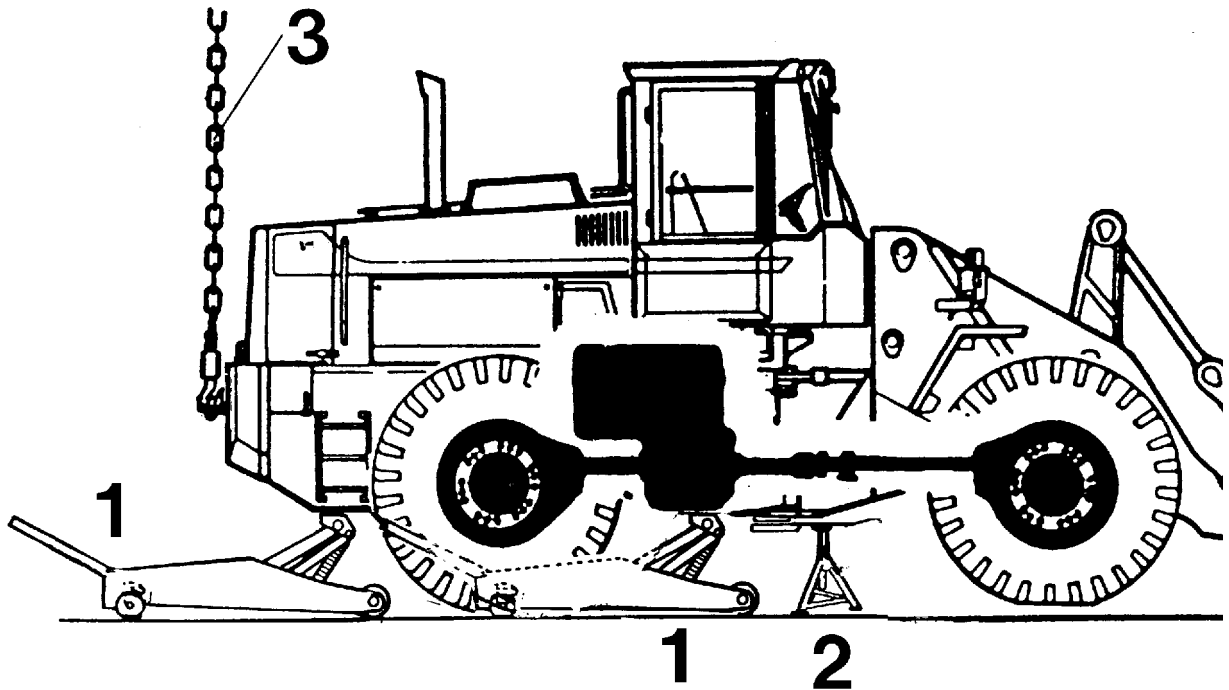
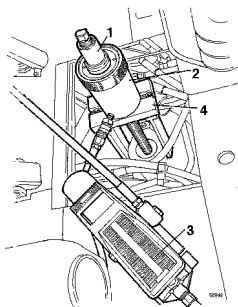

**Figure 5**  
**Securing machine**

1	Jack
2	Axle stand
3	Supporting rear frame with a hoist when parting the machine

**Removing upper pin**

12. Fold up the floor mat and remove the floor plate above the frame joint.
13. Fit the tools on the upper pin according to [Figure 6](#) and pull out the pin.



**Figure 6**  
**Extracting upper pin**

1	3651
---	------

2	11 666 015
3	11 666 013
4	3739

## Removing lower pin

14. Remove the cover and the shims under the pin, see [Figure 7](#).  
Fit the tools to the lower pin according to [Figure 8](#) and pull out the pin.

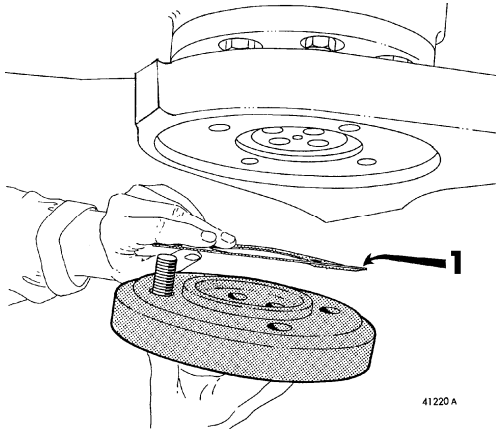

**Figure 7**  
**Removing cover**

1	Shims
---	-------

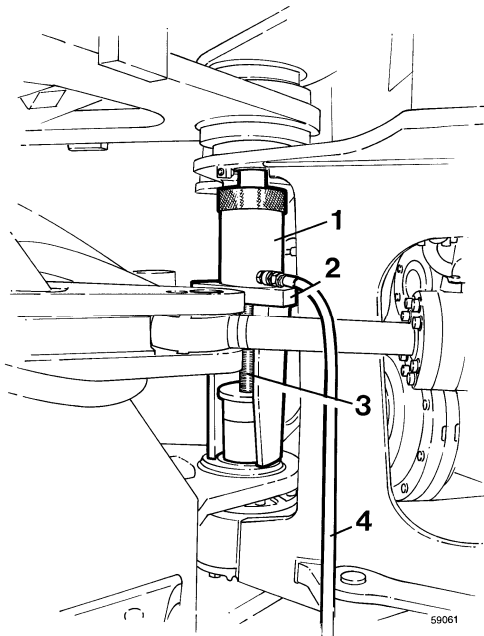

**Figure 8**  
**Extracting lower pin**

1	11 666 015
2	3739
3	3651
4	11 666 013

## Pulling frames apart

15. Make sure that the frame joint is unloaded, i.e. the front and rear frames are supported so that all weight is taken off the frame joint when pulling the frames apart.

Secure the rear frame with the aid of a hoist, see [Figure 5](#).

Force a release of the parking brake by removing the three plugs at the front of the transmission, see [Figure 9](#), and replace them with M10 x 90mm bolts. Use a gasket under the bolt heads.

Screw in the bolts fully by hand.

### NOTE!

Oil runs out until the bolts have been screwed in fully. Therefore, the plugs must be replaced one at a time. Change the other plugs and alternately screw the bolts right in until the brake is released.

16. Press the rear frame rearward with the aid of a bottle-type jack, see [Figure 10](#).

### NOTE!

Make sure that the jacks under the rear frame move with the frame and that the servo hoses are not stretched to breaking point.

17. Position safety supports under the frames.

Apply the parking brake or alternatively position blocks in front of and behind the rear wheels.

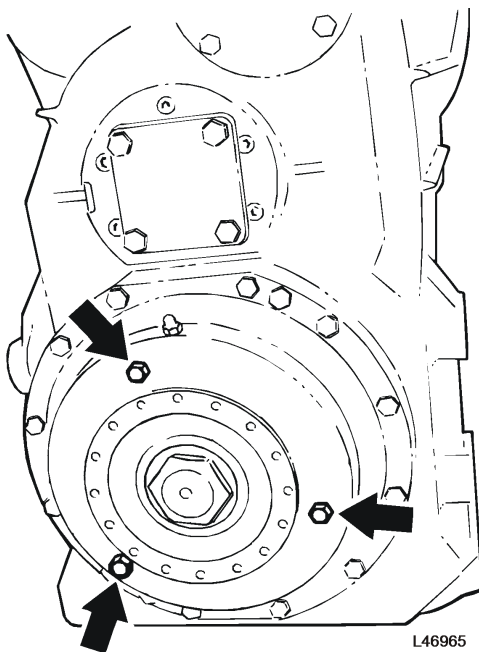

**Figure 9**  
**Forced (manual release) of parking brake**

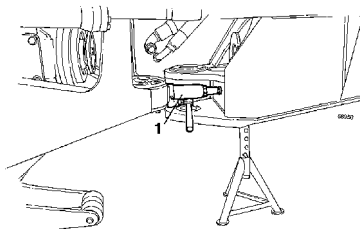

**Figure 10**  
**Parting front and rear frames**

1	Bottle-type jack, 1.5 tonnes
---	------------------------------

## Removing upper bearing



18. Prize away the oil seals, remove the lock rings and press out the link bearing according to [Figure 11](#).

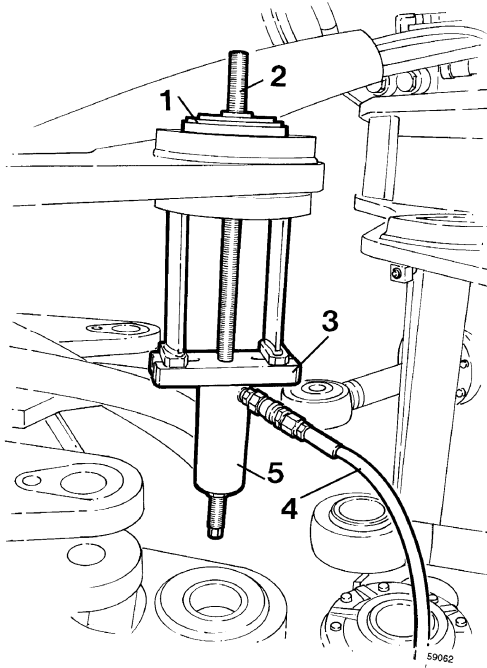

**Figure 11**  
**Pressing out link bearing**

1	11 667 130
2	3713
3	3722
4	11 666 013
5	11666 014

### **Fitting upper bearing**

19. Place the lower lock ring in position.  
Coat the bearing sliding surfaces with grease.  
Press down the bearing against the lock ring, see [Figure 12](#).  
Place the upper lock ring in position.
20. Press the upper and lower oil seals into position according to [Figure 13](#).  
The seals should be turned according to [Figure 27](#).

**Thank you very much for reading.**

**This is part of the demo page.**

**GET MORE:**

**Hydraulic**

**System, Setting**

**Instructions, Functional**

**Description, Electrical**

**System And more.....**

**Click Here BUY NOW**

**Then Instant Download**

**the Complete Manual.**