

Document Title: Engine, description	Function Group: 210	Information Type: Service Information	Date: 2014/11/13
Profile:			

Engine, description

(CUMMINS C8.3-C)

- The engine is a 6-cylinder, 4-stroke, direct injected, turbocharged, water cooled assembly with a cast iron block and cylinder head.
- Gears in the engine gear case are hardened helical type for strength and reduced noise, arranged to provide quiet, smooth transmission of power.
- The cylinder block and head are designed with internal passages formed as sets for lubrication and cooling. The water pump and oil cooler are integrally mounted.
- The fan belt is a poly type V-belt for improved performance and an auto tension adjuster maintains belt tension.

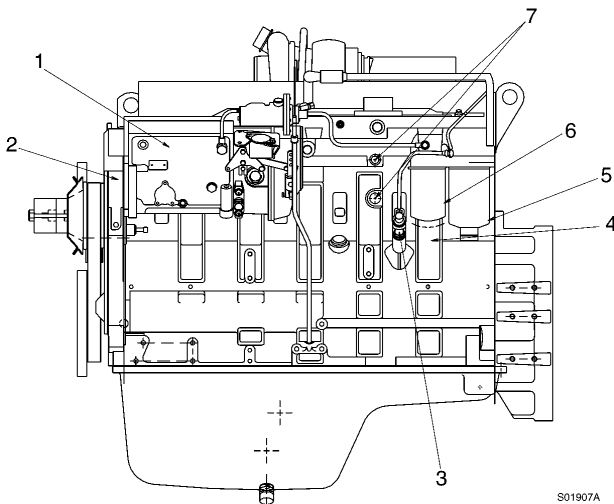

S01907A

Figure 1
Engine, structure

1. Fuel injection pump
2. Engine data plate
3. Fuel feed pump
4. Engine oil pressure sensor port (1/8" NPTF)
5. Fuel primary filter/water separator
6. Fuel secondary filter
7. Water inlet/outlet (1/2" NPTF)

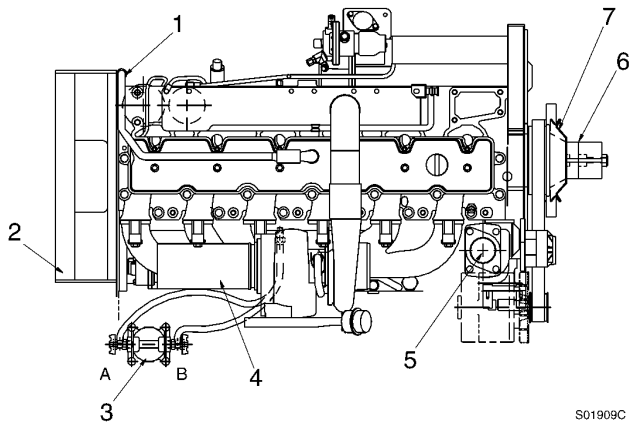

S01909C

Figure 2
Engine, top view

1. Breather hose
2. Flywheel housing
3. Water filter
4. Exhaust gas pipe
5. Thermostat
6. Fan spacer
7. Fan drive pulley

- A. Out
- B. In

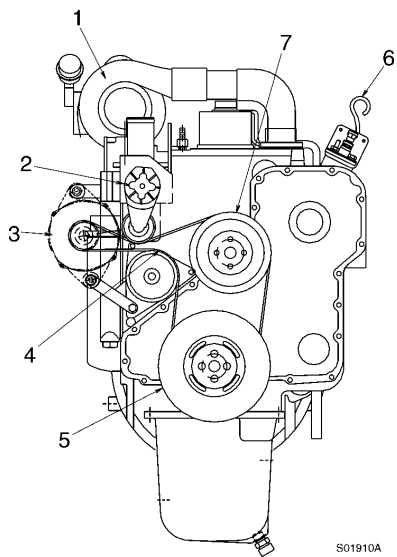

S01910A

Figure 3
Engine, front view

1. Turbocharger
2. Automatic belt tensioner
3. Alternator
4. Fan belt
5. Vibration damper
6. Dipstick gauge
7. Fan drive pulley

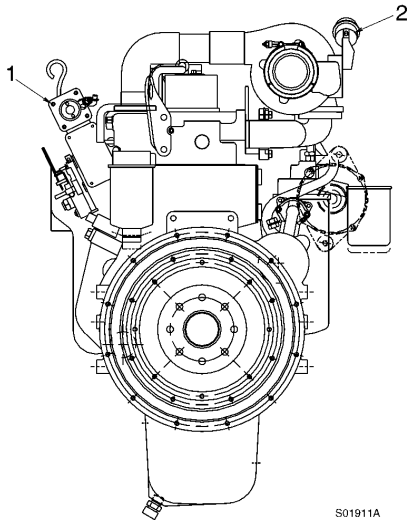

Figure 4
Engine, rear view

1. Fuel shut-off solenoid
2. Turbocharger wastegate

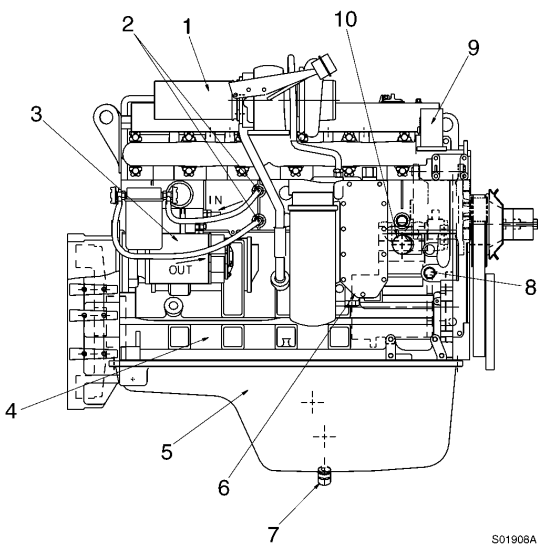

Figure 5
Engine turbocharger, side view

1. Exhaust gas discharge port
2. Water filter connecting port (1/2" NPTF)
3. Starter
4. Engine block
5. Oil pan
6. Engine oil cooler
7. Engine oil drain valve (M18 × 1.5P)
8. Temperature switch (for auto warm - up)
9. Water outlet
10. Water inlet

Engine characteristic curve

Engine characteristics

Item	Specification
------	---------------

Rated output	200 PS / 1900 rpm
Max. torque (Net)	87 kgf·m / 1300 rpm (629 lbf·ft / 1300 rpm)
Min. fuel consumption	155 g / ps·h
Rated fuel consumption	170 g / ps·h

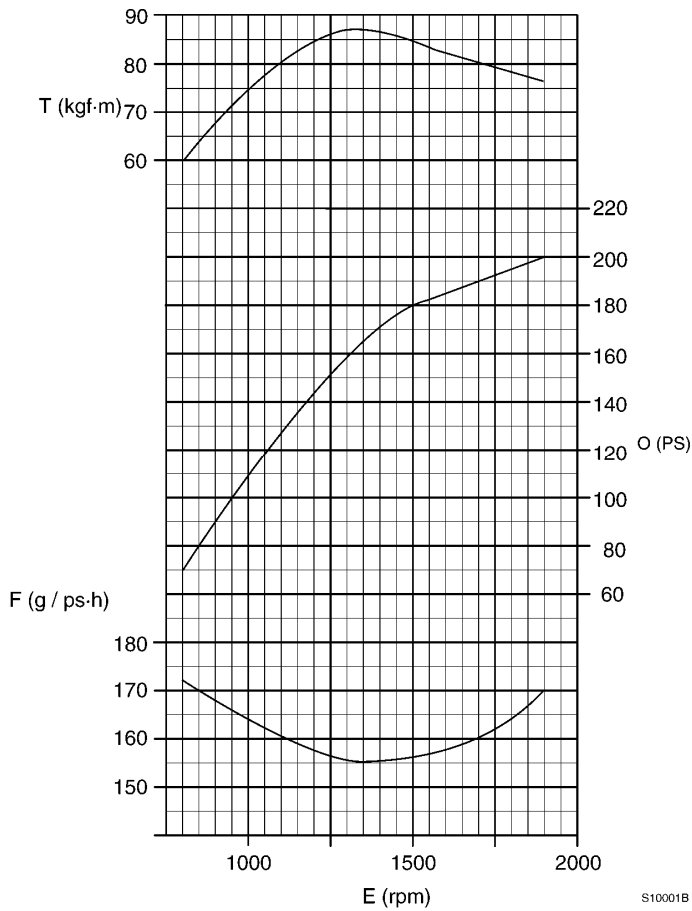

S10001B

Figure 6
Engine, characteristic curve

- T. Torque
- F. Fuel consumption
- O. Output
- E. Engine speed

NOTE!

For detailed information on the engine, consult the separate engine service manual.

Document Title: Valve clearance adjustment	Function Group: 214	Information Type: Service Information	Date: 2014/11/13
Profile:			

Valve clearance adjustment

Cummins C8.3-C

Valve clearance adjustment

Valves must be correctly adjusted for the engine to operate efficiently. Valve adjustment must be performed using the specified values.

Adjust the valves at each 1000 hours or 1 year maintenance interval.

All the valve adjustments must be made when the engine is cold, and stabilized coolant temperature is 60 °C or below.

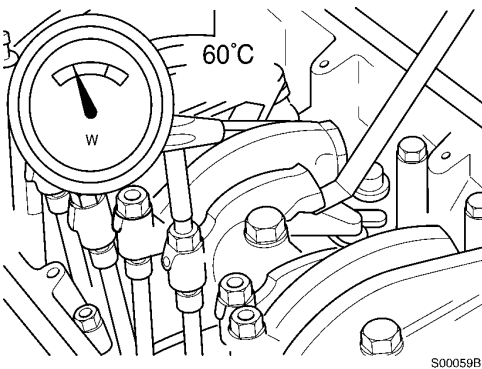

Figure 1
Adjustment condition

W. Water temperature

Valve clearance

Inlet valve	0.30 mm	0.012 in
Exhaust valve	0.61 mm	0.024 in

- Remove the air inlet hose.

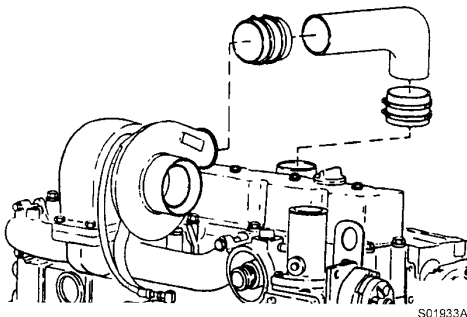

Figure 2
Removal, inlet hose

- Remove the wastegate sensing line, support clamps and crankcase vent tube.

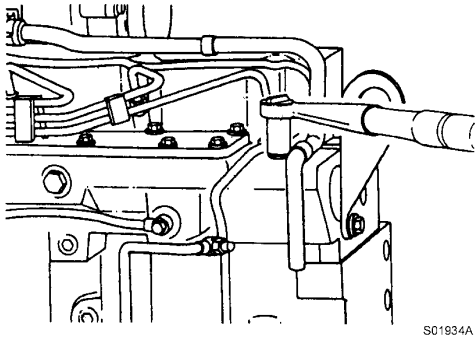

Figure 3
Removal. crankcase vent tube

Tools : 13, 18 mm Socket

- Remove the valve cover.

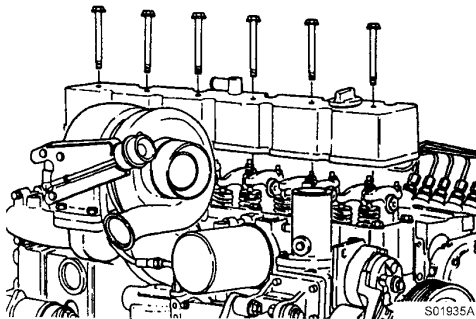

Figure 4
Removal, valve cover

Tools : 15 mm Wrench

- Locate top dead center for cylinder No.1 by rotating the crankshaft slowly while pressing on the engine timing pin.

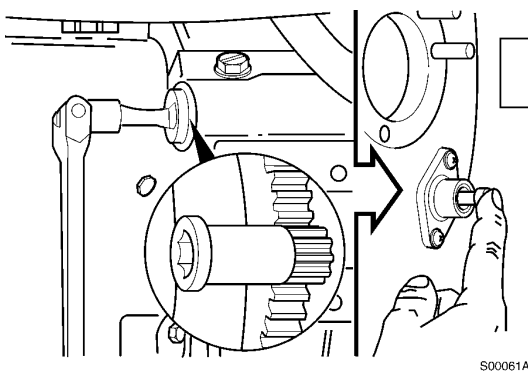
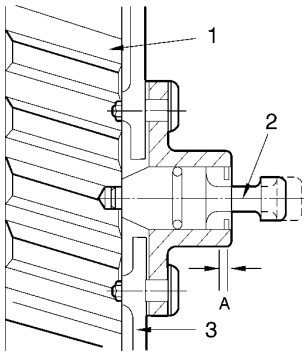

Figure 5
Rotation, camshaft gear

Tools : 1/2" driver, Part No. 3377371 Engine Barring tool.

- When the pin engages the hole in the camshaft gear, cylinder No. 1 is at top dead center on the compression stroke.



S01936A

Figure 6
Position, cylinder No.1

- 1. Camshaft gear
- 2. Engine timing pin
- 3. Gear housing

- A. Compression stroke

! CAUTION

Disengage the timing pin. Engine components may be damaged if the engine is rotated with the timing pin engaged.

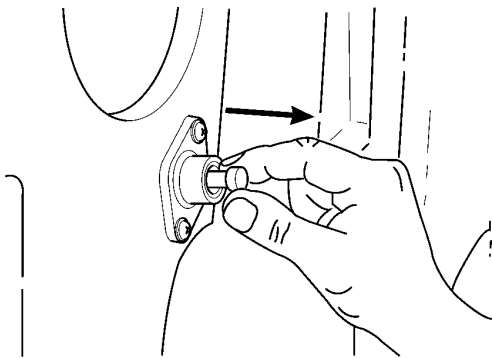

S01937A

Figure 7
Removal, timing pin

! CAUTION

To prevent damage of push rod, make sure the adjusting screw ball is positioned in the socket of the push rod when tightening.

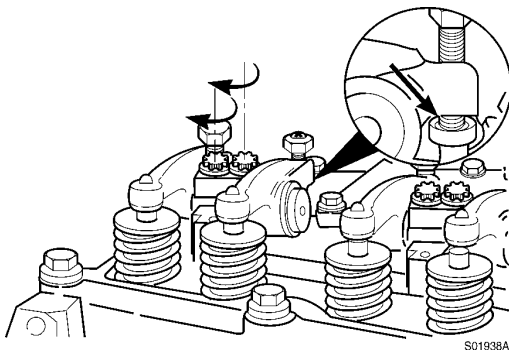

S01938A

Figure 8
Position, adjusting screw ball

- The clearance is correct when slight resistance is felt as the feeler gauge is moved between the valve stem and rocker lever.
At that point, tighten the lock nut.

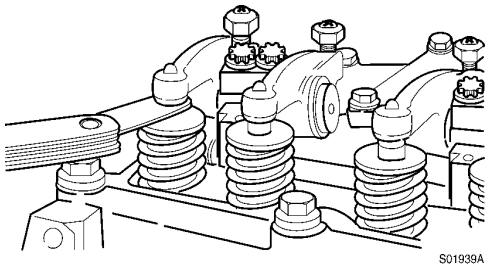

Figure 9
Checking, clearance

Tools : Spanner 14mm, "-" Driver, feeler gauge.

- Adjust the valves indicated (*) in the table below.
After tightening the lock nut, check the valve clearance again.
If the clearance is not correct, readjust.

Valves to be adjusted (*)

Cylinder	1	2	3	4	5	6
Inlet (I)	*	*		*		
Exhaust (E)	*		*		*	

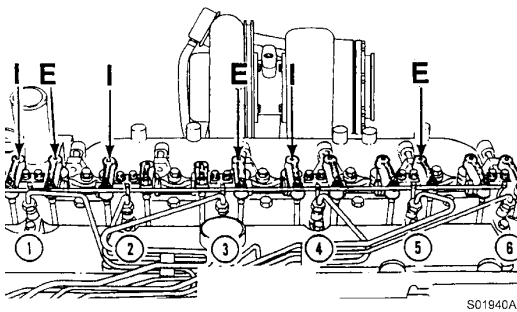

Figure 10
Valves to be adjusted



Be sure the timing pin is disengaged.

- Mark the crankpulley and cover.
- Rotate the crankshaft 360°.

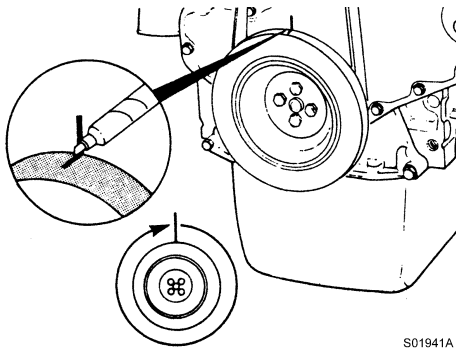

Figure 11
Marking, crankpulley

- Adjust the valves indicated (*) in the table below.
 After tightening the lock nut, check the valve clearance again.
 If the clearance is not correct, readjust.

Valves to be adjusted (*)

Cylinder	1	2	3	4	5	6
Inlet (I)		*		*	*	
Exhaust (E)		*		*		*

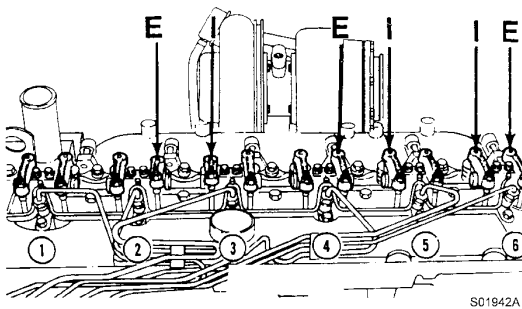

Figure 12
Valves to be adjusted

Valve cover–installation

- Install the rubber seal into the groove in the valve cover. Start the installation at the overlap area shown in the illustration.

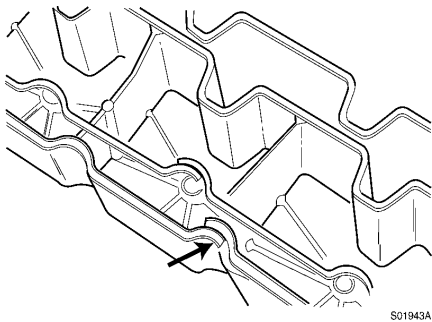

Figure 13
Assembly, rubber seal

- Do not stretch the rubber seal. If the seal has more overlap than shown in this illustration, trim the excess to provide the proper overlap.
- Install new o-rings on the valve cover screws.

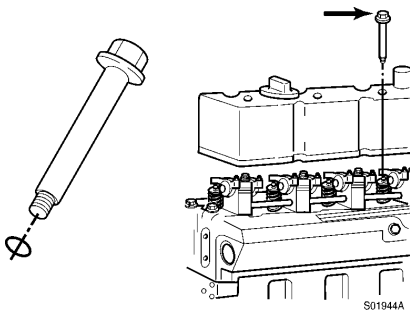

Figure 14
Assembly, o-ring

NOTE!

Engines equipped with wastegate turbochargers must have a studded screw installed in the third hole from the front. This is for the wastegate actuator hose clamp.

- Install the valve cover screws and tighten in the sequence shown.

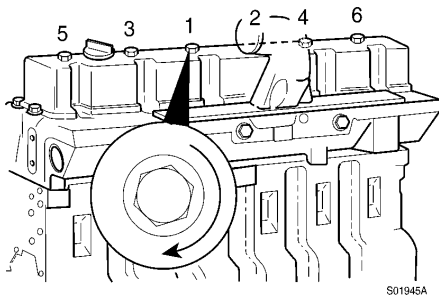

Figure 15
Screw tightening sequence

Tools : 15 mm spanner
Tightening torque : 24 N·m (18 lbf·ft)

Crankcase breather tube–installation

- Install the breather tube and hose clamps.
- Tighten the screws for the breather tube support brackets.

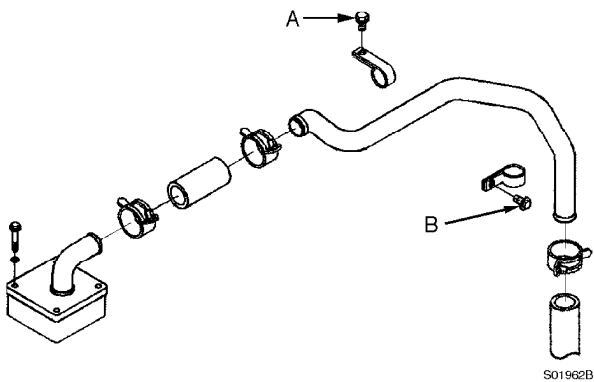

Figure 16
Assembly, breather tube

Tightening torque : A = 24 N·m (18 lbf·ft), B = 43 N·m (32 lbf·ft)
Tools : 13, 18 mm spanner

Injection nozzles–installation

- Lubricate the sealing lips of the sleeve with anti-seize compound. Assemble the injection nozzle, the sealing sleeve, a new copper washer and the hold-down clamp.
- Use only one washer.
- A light coat of clean 15W-40 engine oil between the washer and the injection nozzle will aid in holding the washer in place during installation.

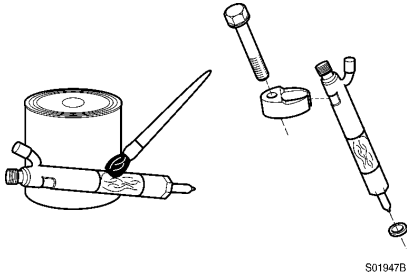

Figure 17
Apply, anti-seize compound

- Install the hold-down injection nozzle assembly into the injection nozzle bore. The injector leak-off connection must be toward the valve cover.

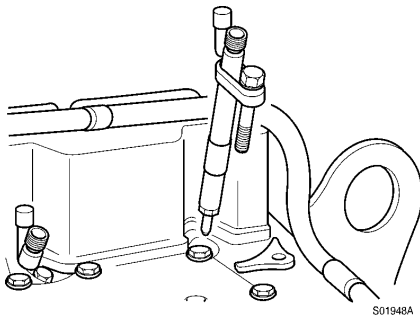

Figure 18
Assembly, injection nozzle

- Install the hold-down screw.

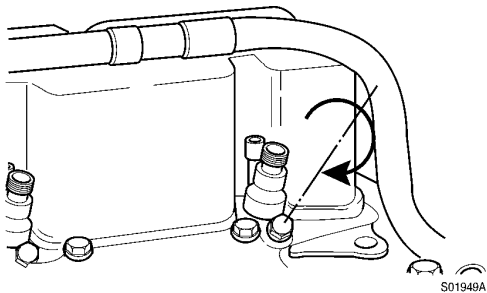

Figure 19
Screw in, hold-down screw

Tightening torque : 24 N·m (18 lbf·ft)

Tools : 13 mm spanner

Document Title: Engine mounting	Function Group: 218	Information Type: Service Information	Date: 2014/11/13
Profile:			

Engine mounting

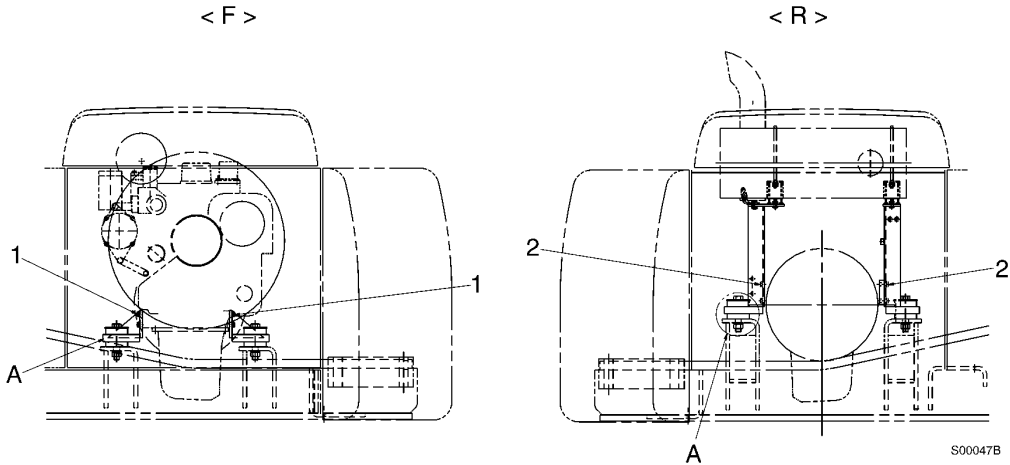

Figure 1
Engine mounting, side view

- A : Cushion
- F : Front-fan side view
- R : Rear- flywheel side view

Tightening torque, unit : kgf-m (lbf-ft)

No.	Mounting position	Tightening torque
1	Engine mounting bracket (front)	M12 x 1.75 x 35L
		11 ~ 12 (79 ~ 87)
2	Engine mounting bracket (rear)	M12 x 1.75 x 50L
		7.2 ~ 8.4 (52 ~ 61)
3	Engine mounting cushion	M22 x 2.5 x 130L
		63 ~ 77 (455 ~ 557)

NOTE!

Check the color markings for cushion installation.

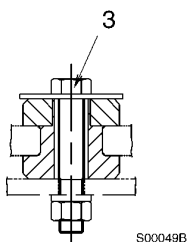

Figure 2
Cushion (A - detail)

- Front (fan side)—Green and white
- Rear (flywheel side)—Violet and white

Document Title: Lubricating description	system, 220	Function Group: 220	Information Type: Service Information	Date: 2014/11/13
Profile:				

Lubricating system, description

- Engine lubricating oil is supplied to the contact faces of rotating components such as turbocharger, crankshaft, camshaft, piston, inlet/exhaust valve, rocker arm and timing gear by means of forced lubrication from the oil pump.

Lubricating oil flow diagram

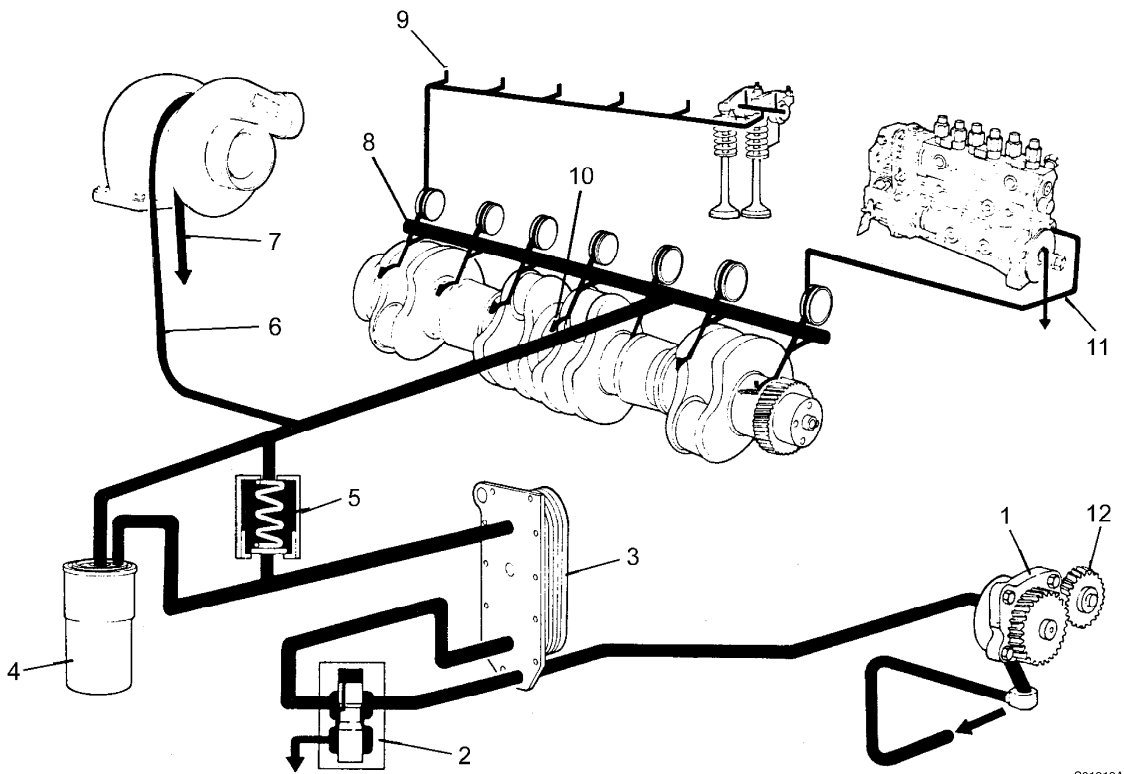

S01919A

Figure 1
Lubrication oil flow

1. Oil pump
2. Pressure regulating valve
3. Oil cooler
4. Oil filter
5. Filter bypass valve
6. Turbocharger oil supply
7. Turbocharger oil drain
8. Main oil supply circuit
9. Rocker lever oil supply (#7 cam bushing)
10. Piston cooling nozzle
11. Injection pump oil supply (#1 cam bushing)
12. Oil pump idler gear

Document Title: Fuel injection system	Function Group: 230	Information Type: Service Information	Date: 2014/11/13
Profile:			

Fuel injection system

- Highly pressurized fuel compressed by the fuel injection pump is direct injected through the injection nozzle into the combustion chamber.
- Remaining fuel after injection is returned to tank automatically.
- A water separator installed to protect the fuel system components provides a means to drain off the water and contaminants collected from the system.

Fuel flow system diagram

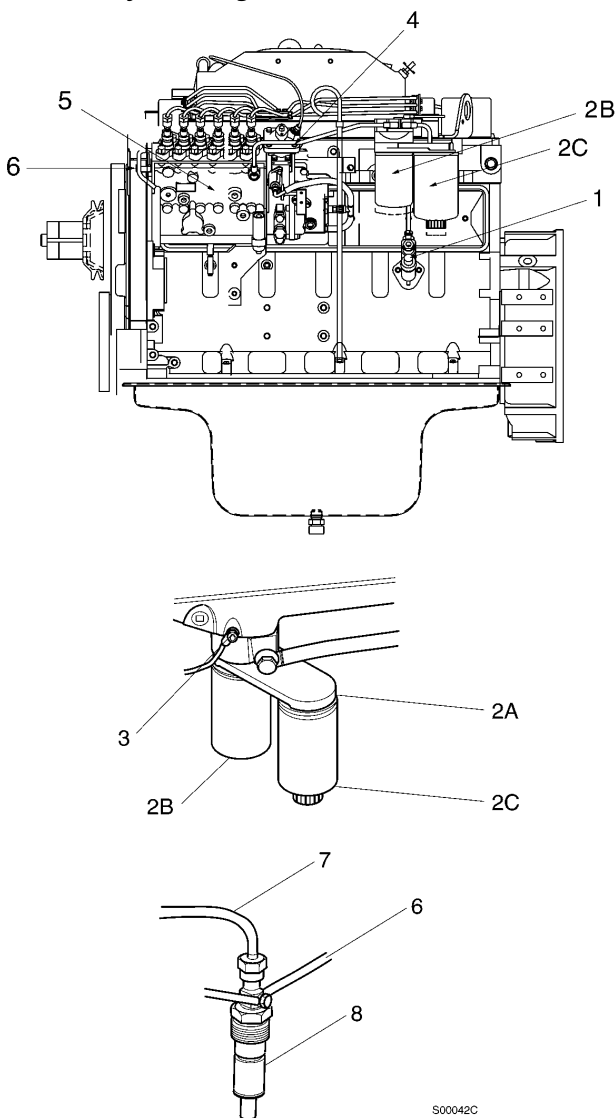

Figure 1
Fuel flow system

1. Fuel feed pump
2. Fuel filter

- 2A. Filter bracket
- 2B. Secondary fuel filter
- 2C. Primary fuel filter/water separator

- 3. Bleed screw
- 4. Low pressure supply line
- 5. Fuel injection pump
- 6. Remaining fuel drain lines
- 7. High pressure fuel supply line
- 8. Fuel injection nozzle

**Thank you very much
for your reading.**

**Please click here and go
back to the website.**

**Then, you can
download the complete
manual instantly.**

No waiting.

Document Title: Fuel tank, description	Function Group: 2341	Information Type: Service Information	Date: 2014/11/13
Profile:			

Fuel tank, description

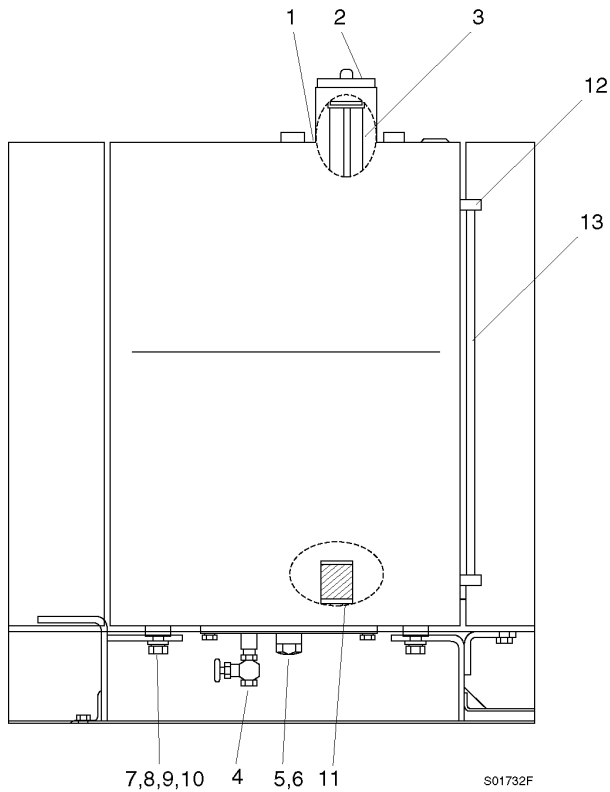

Figure 1
Structure, fuel tank

1	Tank	8	Plain washer
2	Cap	9	Spring washer
3	Screen	10	Shim
4	Drain cock	11	Strainer
5	Plug	12	Screw
6	O-ring	13	Level gauge
7	Screw		

- When mounting the tank, adjust the height by use of shim (10).

Tightening torque :

- Screw (7) : 52.2 ± 5.2 kgf·m (377 ± 38 lbf·ft)
- Drain cock(4) : 1.6 ~ 1.9 kgf·m (11.6 ~ 13.7 lbf·ft)
- Screw(12) : 1.5 ± 0.2 kgf·m (10.8 ± 1.4 lbf·ft)

Document Title: Fuel filling pump, description	Function Group: 2344	Information Type: Service Information	Date: 2014/11/13
Profile:			

Fuel filling pump, description

- The pump outlet is plumbed directly to the fuel tank to reduce the risk of introducing contamination.
- The master switch must be in the ON position to operate the fuel filling pump.

CAUTION

The filter at the end of fuel filling pump inlet hose is a strainer, and will not filter impurities from the fuel. When filling use CLEAN fuel only!

CAUTION

Do not operate the fuel filling pump without fuel or for extended periods of time.

CAUTION

Drain the fuel from the suction hose before putting it in the storage compartment.

CAUTION

In case of the pump has been disassembled, assemble the pump so the that the sharp portion of the vane faces the counterclockwise direction.

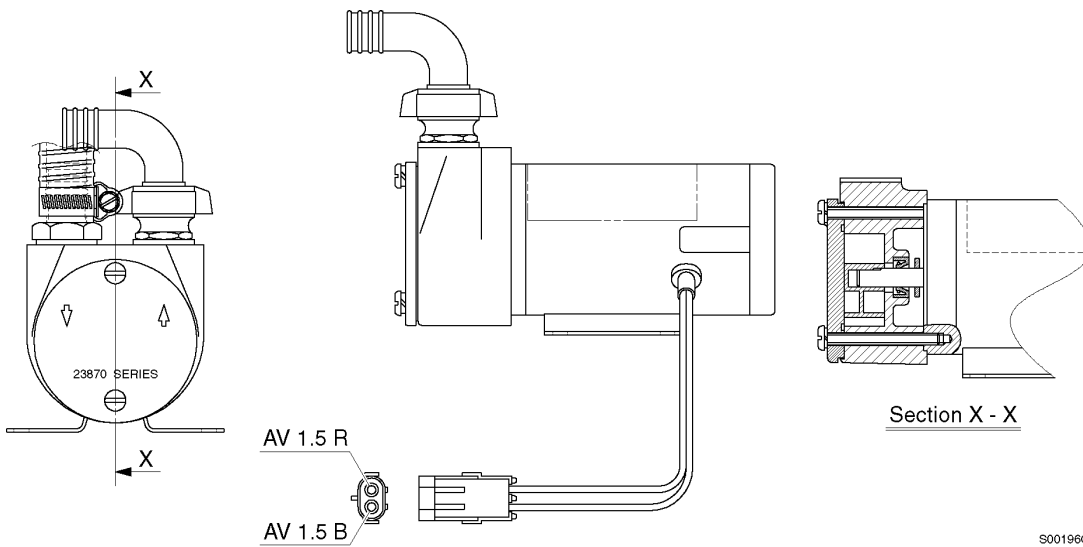

S00196C

Figure 1
Structure, fuel filling pump (35 liter)

X : Section X - X