

STIHL Components 4140
FC, FS, HL, KM

2003-10

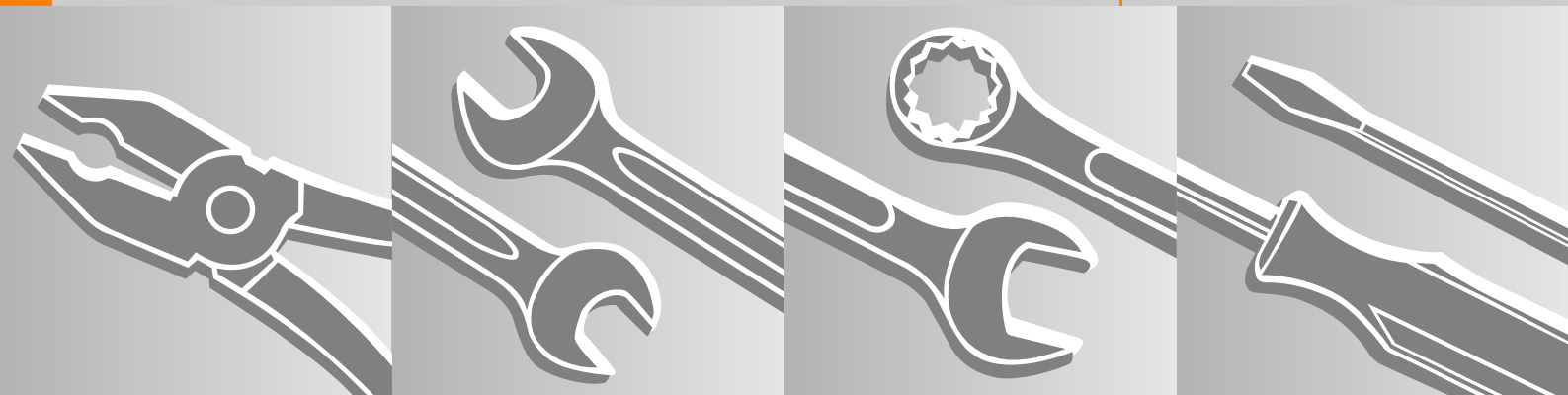

Contents

1.	Introduction	2	7.	Throttle Control	26	9.2.4	Fixed Jet	44
2.	Safety Precautions	3	7.1	Control Handle on Bike Handle (except HL)	26	9.3	Adjusting the Carburetor	44
3.	Specifications	4	7.1.1	Throttle Trigger/Interlock Lever (up to 2001)	26	9.3.1	Carburetor with LD Screw	44
3.1	Fuel System	4	7.1.2	Throttle Trigger/Interlock Lever (from 2001)	27	9.3.2	Carburetor with H, L and LA Screws	45
3.2	Gearboxes	4	7.1.3	Contact/Detent Springs (up to 2001)	28	9.3.3	Basic Setting on Carburetor with H, L and LA screws	47
3.2.1	FS Units	4	7.1.4	Contact/Detent Springs (from 2001)	28	9.4	Tank Vent	48
3.2.2	HS 45	4	7.1.5	Replacing the Throttle Cable	29	9.4.1	General	48
3.3	Tightening Torques	5	7.2	Control Handle and Separate Loop Handle (FS 46, 55 only)	30	9.4.2	Replacing	48
4.	Troubleshooting	7	7.2.1	Throttle Trigger/Interlock Lever/Stop Switch	30	9.5	Fuel Tank	49
4.1	Clutch, Blade Lock	7	7.2.2	Replacing the Throttle Cable	32	9.5.1	Removing and Installing	49
4.2	Rewind Starter	8	7.3	Integrated Control Handle	33	9.5.2	Pickup Body/Hoses	50
4.3	Fuel System	9	7.3.1	Throttle Trigger/Interlock Lever	33	10.	Drive Tube	51
4.4	Engine	12	7.3.2	Stop Switch	34	10.1	Removing and Installing	51
5.	Engine	13	7.3.3	Short Circuit Wire/ Ground Wire	34	10.2	Parts on Drive Tube	52
5.1	Shroud	13	7.3.4	Replacing the Throttle Cable	35	10.2.1	Bike Handle	52
5.2	Clutch	13	7.4	Adjusting the Throttle Cable	36	10.2.2	Loop Handle without Barrier Bar (not KM 55)	53
5.3	Removing and Installing the Engine	15	7.5	Insulating the Throttle Cable	36	10.2.3	Loop Handle with Barrier Bar	53
5.4	Muffler/Spark Arresting Screen	16	8.	Fuel System	37	10.2.4	Loop Handle	53
5.4.1	Version without Catalytic Converter	17	8.1	Air Filter	37	10.2.5	Deflector (FS 45, 46 only)	54
5.4.2	Version with Catalytic Converter (up to 2003)	17	8.1.1	Removing and Installing	37	10.2.6	Carrying Rings	54
5.4.3	Version with Catalytic Converter (from 2003)	19	8.1.2	Choke Shutter	37	10.2.7	Throttle Cable Retainer and Sleeve	54
5.5	Spacer	20	8.2	Carburetor	38	10.3	Disassembling and Assembling	55
6.	Rewind Starter	20	8.2.1	Leakage Test	38	10.3.1	Split Drive Tube (FS 55T only)	55
6.1	General	20	8.2.2	Removing and Installing	39	10.3.2	Drive Tube (FS 45, 46 only)	57
6.2	Removing and Installing	20	8.2.3	Spacer Flange	40	10.3.3	Drive Tube (FS 55, FC 55, HL 45 only)	57
6.3	Starter Cup	21	9.	Servicing the Carburetor	41	10.4	Gearbox	58
6.4	Rope Rotor	21	9.1	Pump Diaphragm/ Fuel Strainer	41	11.	Special Servicing Tools	59
6.5	Replacing the Rewind Spring	22	9.2	Manual Fuel Pump with Oval End Cover	41	12.	Servicing Aids	60
6.6	Tensioning the Rewind Spring	23	9.2.1	Manual Fuel Pump with Square End Cover	42			
6.7	Starter Rope	24	9.2.2	Metering Diaphragm	43			
6.8	Pawl	24	9.2.3	Inlet Needle	43			
6.9	Starter Rope Guide Bush	25						

STIHL[®]

© ANDREAS STIHL AG & Co. KG, 2003

1. Introduction

This service manual contains detailed descriptions of all typical repair and servicing procedures for models FS 45, 46, 55, FC 55, HL 45 and KM 55, which are based on the series 4140 powerhead.

If there is no specific reference to individual machines, the procedure is the same for all machines. The illustrations may differ depending on the machine, but the methods used and the sequence of operations are identical.

You will find detailed descriptions of procedures for servicing and repairing engine components and associated CombiTools in the service manual for the "Series 4140 Powerhead".

You should make use of the illustrated parts lists while carrying out repair work. They show the installed positions of the individual components and assemblies.

Refer to the latest edition of the relevant parts list to check the part numbers of any replacement parts.

A fault on the machine may have several causes. To help locate the fault, consult the chapter on "Troubleshooting" in this manual and the "STIHL Service Training System" for all assemblies.

Refer to the "Technical Information" bulletins for engineering changes which have been introduced since publication of this service manual. Technical information bulletins also supplement the parts list until a revised edition is issued.

The special servicing tools mentioned in the descriptions are listed in the chapter "Special Servicing Tools" of this manual. Use the part numbers to identify the tools in the "STIHL Special Tools" manual. The manual lists all special servicing tools currently available from STIHL.

Symbols are included in the text and pictures for greater clarity. The meanings are as follows:

In the descriptions:

● = Action to be taken as shown in the illustration (above the text)

– = Action to be taken that is not shown in the illustration (above the text)

↪ = Situation applies from serial number

→ = Situation applies up to serial number

📖 4.2
Reference to another chapter, i.e. chapter 4.2 in this example.

In the illustrations:

➡ Pointer

➡ Direction of movement

Service manuals and technical information bulletins are intended exclusively for the use of properly equipped repair shops. They must not be passed to third parties.

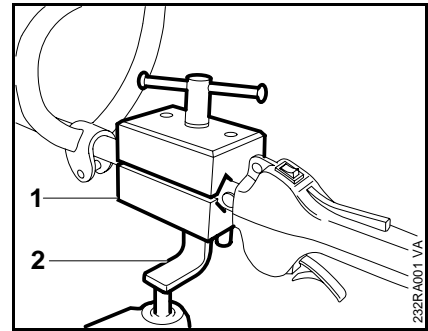

Servicing and repairs are made considerably easier if the machine is mounted on assembly stand (2) 5910 890 3100 with the aid of clamping fixture (1) 5910 890 3100.

Mount the clamping fixture to the assembly stand with two washers and two M8 nuts. The powerhead can then be swivelled to the best position for the ongoing repair. This leaves both hands free.

Always use original STIHL replacement parts.

They can be identified by the STIHL part number, the **STIHL** logo and the STIHL parts symbol . This symbol may appear alone on small parts.

2. Safety Precautions

If the engine is started up in the course of repairs or maintenance work, observe all local and country-specific safety regulations as well as the safety precautions and warnings in the instruction manual.

Gasoline is an extremely flammable fuel and can be explosive in certain conditions.

Improper handling may result in burns or other serious injuries.

Warning!

Do not bring any fire, flame, spark or other source of heat near the fuel. All work with fuel must be performed outdoors only. Spilled fuel must be wiped away immediately.

3. Specifications

3.1 Fuel System

Carburetor:	Diaphragm carburetor
Carburetor leakage test at gauge pressure:	0.8 bar (11.6 psi)
Operation of tank vent at gauge pressure:	0.3 bar (4.4 psi)
under vacuum:	0.05 bar (0.725 psi)
Fuel:	see instruction manual
Octane number:	min. 90 RON (USA/CAN: pump octane min. 87 unleaded)
Fuel mixture:	Regular brand-name gasoline and STIHL 50:1 two-stroke engine oil or brand-name 25:1 two-stroke engine oil
Mix ratio:	50:1 with STIHL 50:1 two-stroke engine oil
	Fuel mix for units with catalytic converter: Use only STIHL 50:1 two-stroke engine oil with unleaded gasoline.

3.2 Gearboxes

3.2.1 FS Units

Type:	Spiral-toothed bevel drive gear
Gear ratio:	1:1.235
Bearings:	Deep groove ball bearings
Lubrication:	STIHL gear lubricant for brushcutters

3.2.2 HS 45

Type:	Straight-toothed spur gear drive gear
Gear ratio:	1:5.1
Bearings:	Deep groove ball bearings
Lubrication:	STIHL gear lubricant for hedge trimmers

3.3 Tightening Torques

DG and P (Plastoform) screws are used in polymer and light metal components. These screws form a permanent thread when they are installed for the first time. They can be removed and installed as often as necessary without impairing the strength of the screwed assembly, providing the specified tightening torque is observed.

For this reason it is **essential to use a torque wrench**.

Fastener	Thread size	For component	Torque		Remarks
			lbf.ft	Nm	
Screw	B3.9x19	Control handle/right/left switch housing molding/US loop handle	1.8	2.5	1)2)
Screw	IS-P4x16	Control handle/right/left handle molding (bike handle)	0.75	1.0	1)
Screw	IS-M5x30	Control handle to handlebar with washer (bike handle)	1.5	2.0	1)
Nut	M5	Filter housing/carburetor/spacer flange	2.6	3.5	1)2)3)4)5)
Screw	IS-M6x35	Clamp/handle support/clamp (bike handle)	3.3	4.5	1)
Wing screw	M6x30	Coupling sleeve/wing screw (T model)	4.4	6.0	1)
Screw	IS-M6x25	Coupling sleeve/clamp nut (T model)	6.6	9.0	1)
Screw	IS-8-32	Clutch drum/crankshaft	3.0	4.0	1)2)3)4)5)
Screw	IS-M6x25	Clamp/loop handle/square nut (loop-handled machine)	3.3	4.5	1)4)5)
Carrier	3/8"-24	Carrier/crankshaft	12.5	17.0	1)2)3)4)5)
Screw	IS-DG5x24	Engine housing/clutch drum mounting	1.5	2.0	1)2)3)4)5)
Screw	IS-DG5x24	Engine housing/shroud	3.3	4.5	1)2)3)4)5)
Screw	IS-DG5x24	Engine housing/crankcase	5.9	8.0	1)2)3)4)6)
Collar screw	P3.5x9.0	Detent spring/slide control (bike handle)	0.8	1.1	1)
Screw	IS-DG5x60	Muffler/cylinder	6.6	9.0	1)2)3)4)5)
Screw	IS-DG5x24	Muffler/cylinder (catalytic converter)	6.6	9.0	1)2)3)4)
Screw	IS-DG5x12	Centering drive tube/engine housing	3.0	4.0	1)2)3)4)5)
	M14x1.25	Spark plug	15.0	20.0	

Remarks:

- 1) FS 55
- 2) FS 46
- 3) FS 45
- 4) KM 55, FC 55
- 5) HL 45
- 6) with binding head

Fastener	Thread size	For component	Torque		Remarks
			lbf.ft	Nm	
Screw	IS-M6x14	Clamp/drive tube/harness ring	3.3	4.5	1)
Screw	IS-DG5x20Z	Rewind starter/crankcase	4.4	6.0	1)2)3)4)5)
Screw	IS-DG5x20Z	Rewind starter/engine pan	4.4	6.0	1)2)3)4)5)
	M8x1	Starter cup/crankshaft	10.3	14.0	1)2)3)4)5)
	M14x7	Stub/muffler (version with spark arresting screen in muffler)	7.5	10.0	1)2)3)4)5)6)
Screw	IS-P5x20	Tank housing/retainer	1.5	2.0	1)2)3)4)5)
Screw	IS-DG5x24	Spacer flange/cylinder	4.4	6.0	1)2)3)4)5)6)
Screw	IS-M5x8	Clamp/drive tube/guide	5.9	8.0	2)3)
Screw	IS-DG5x24	Engine housing/crankcase	6.6	9.0	5)

Remarks:

- 1) FS 55
- 2) FS 46
- 3) FS 45
- 4) KM 55, FC 55
- 5) HL 45
- 6) with binding head

Use the following procedure when refitting a DG or P screw in an existing thread:

- Place the screw in the hole and rotate it counterclockwise until it drops down slightly.
- Tighten the screw clockwise to the specified torque.

This procedure ensures that the screw engages properly in the existing thread and does not form a new thread and weaken the assembly.

Power screwdriver settings for polymer:	Plastoform screws	max. 600 rpm
	DG screws	max. 500 rpm

Important:

Do not mix up screws with and without binding head

4. Troubleshooting
4.1 Clutch, Blade Lock

Condition	Cause	Remedy
Tool stops at full throttle under load	Clutch shoes badly worn	Install new clutch shoes or a new clutch
	Clutch drum badly worn	Replace clutch drum
Tool runs at idle speed	Idle speed too high	Readjust idle speed screw (counterclockwise)
	Clutch springs stretched or fatigued	Fit new clutch springs
	Spring hooks broken	Fit new clutch springs
Loud noises	Clutch springs stretched or fatigued	Replace all clutch springs
	Clutch shoe retainer (carrier) broken	Fit new retainer (carrier) or clutch
	Clutch shoes and carrier worn	Install a new clutch
Hedge trimmer blades run in starting throttle position with the blade lock engaged	Tension spring broken	Replace tension spring
	Brake band stretched/worn/broken	Replace brake band

4.2 Rewind Starter

Condition	Cause	Remedy
Starter rope broken	Rope pulled out too vigorously as far as stop or over edge, i.e. not vertically	Fit new starter rope
	Normal wear	Fit new starter rope
Rewind spring broken	Spring overtensioned – no reserve when rope is fully extended	Fit new rewind spring
	Very dirty or corroded	Fit new rewind spring
Starter rope can be pulled out almost without resistance (crankshaft does not turn)	Guide peg on pawl or pawl itself is worn	Fit new pawl
	Spring clip fatigued	Fit new spring clip
Starter rope is difficult to pull and rewinds very slowly	Starter mechanism very dirty (dusty conditions)	Thoroughly clean complete starter mechanism
	Lubricating oil on rewind spring becomes viscous at very low outside temperatures (spring windings stick together)	Coat rewind spring with a standard solvent-based degreasant (containing no chlorinated or halogenated hydrocarbons). Then pull rope carefully several times until normal action is restored

4.3 Fuel System

Condition	Cause	Remedy
Engine stalls at idle speed	Idle jet bores or ports blocked	Clean jet bores and ports and blow clear with compressed air
	Idle jet (L) too rich or too lean	Reset low speed screw (L) correctly
	Setting of idle speed screw (LA) incorrect – throttle shutter completely closed	Reset idle speed screw (LA) correctly
Engine speed drops quickly under load – low power	Air filter plugged	Clean the air filter or replace if necessary
	Tank vent faulty	Fit new tank vent
	Leak in fuel line between tank and fuel pump	Seal or renew connections and fuel line
	Pump diaphragm damaged or fatigued	Fit new pump diaphragm
	Main jet bores or ports blocked	Clean the bores and ports
	Fuel pickup body dirty	Install new pickup body
	Setting of high speed screw (H) too rich	Reset high speed screw (H) correctly
	Throttle shutter not opened fully	Check linkage

Condition	Cause	Remedy
Poor acceleration	Idle jet too lean	Turn low speed screw (L) counter-clockwise (richer), no further than stop
	Main jet too lean	Turn high speed screw (H) counter-clockwise (richer), no further than stop
	Inlet control lever too low (relative to correct installed position)	Set inlet control lever flush with top of carburetor body
	Inlet needle sticking to valve seat	Remove inlet needle, clean and refit
	Connecting bore to atmosphere blocked	Clean the bore
	Diaphragm gasket leaking	Fit new diaphragm gasket
	Metering diaphragm damaged or shrunk	Fit new metering diaphragm
Engine will not idle – idle speed too high	Throttle shutter opened too wide by idle speed screw	Reset idle speed screw correctly

Condition	Cause	Remedy
Carburetor floods, engine stalls	Inlet needle not sealing. Foreign matter in valve seat or cone damaged	Remove and clean or replace inlet needle, clean fuel tank, pickup body and fuel line if necessary
	Inlet control lever sticking on spindle	Free off inlet control lever
	Helical spring not located on nipple of inlet control lever	Remove inlet control lever and refit correctly
	Perforated disc on diaphragm is deformed and presses constantly against inlet control lever	Fit new metering diaphragm
	Inlet control lever too low (relative to correct installed position)	Fit new inlet control lever

4.4 Engine

Always check and, if necessary, repair the following parts before looking for faults on the engine:

- Air filter
- Fuel system
- Carburetor
- Ignition system¹⁾

Condition	Cause	Remedy
Engine does not start easily, stalls at idle speed, but operates normally at full throttle	Oil seals in crankcase faulty	Install new oil seals ¹⁾
	Crankcase leaking / damaged (cracks)	Seal / replace the crankcase ¹⁾
	Muffler leaking	Seal / replace the muffler
Engine does not deliver full power or runs erratically	Piston rings worn or broken	Install new piston rings ¹⁾
	Muffler / spark arresting screen carbonized	Clean muffler (inlet and exhaust openings), replace spark arresting screen
	Air filter element dirty	Fit new air filter element
	Fuel / impulse line kinked or cracked	Fit new lines or position without kinks
Engine overheating	Insufficient cylinder cooling. Air inlets in fan housing blocked or cooling fins on cylinder very dirty	Thoroughly clean all cooling air passages and cooling fins

¹⁾ see "Series 4140 Powerhead" service manual

5. Engine

5.1 Shroud

Only the **new** shrouds with reflector foil for catalytic converter units from 2003 are available as replacements for all machine versions (except HL 45). They are equipped with a reflector foil to protect the shroud from high temperatures. Read the instructions in this chapter before mounting the new version of the shroud.

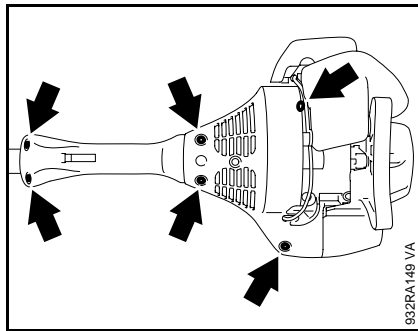

Machines with loop handle

- Remove the screws (arrows) from the shroud.

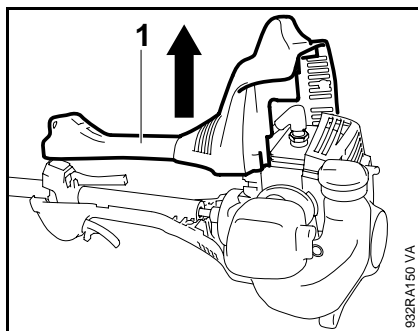

- Lift away the shroud (1).

Install in the reverse sequence.

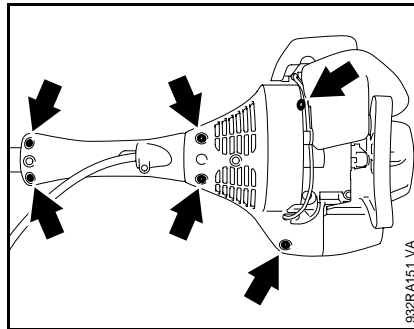

Machines with bike handle

- Remove the screws (arrows) and lift away the shroud.

Install in the reverse sequence.

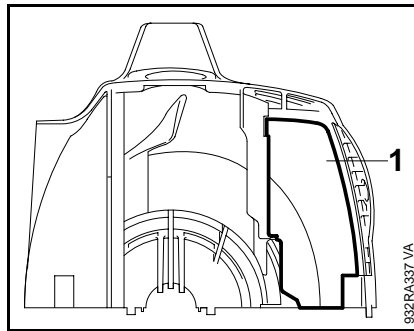

Version with catalytic converter from 2003

- Check that reflector foil (1) is correctly seated before installing the shroud.

5.2 Clutch

Troubleshooting, 4.1

Removing

Remove the engine, 5.3

- Remove the spark plug.
- Use locking strip 4221 893 5900 to block the piston.

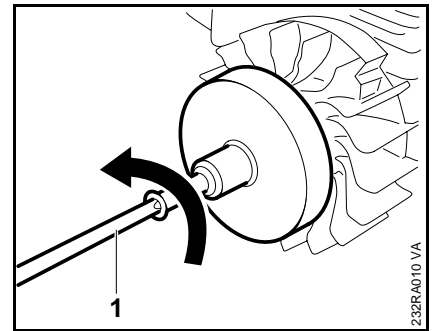

- Use screwdriver bit (1) 0812 540 1112 to unscrew the clutch drum.

– Remove the clutch drum.

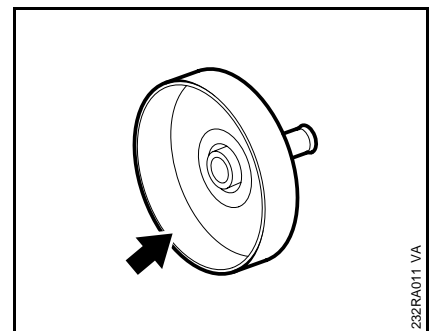

- Inspect the clutch drum. There should be no scores or signs of excessive wear.

BUY NOW

**Then Instant Download
the Complete Manual
Thank you very much!**