

**John Deere
JD862
Scraper**

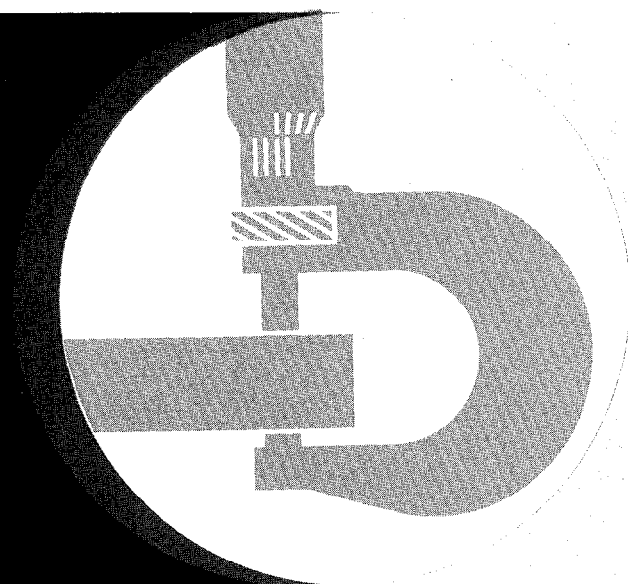

TECHNICAL MANUAL

TM-1212

LITHO IN U.S.A. (T) New

JD862 SCRAPER
Technical Manual
TM-1212 (Sep-84)

SECTION AND GROUP CONTENTS OF THIS MANUAL

SECTION I - GENERAL INFORMATION

- Group I - Contents, Index and Page List
- Group II - Introduction and Safety Information
- Group III - General Specifications
- Group IV - Predelivery, Delivery, and After-Sale Services
- Group V - Fuels and Lubricants

SECTION 1 - WHEELS

- Group 0110 - Powered Wheels and Fastenings
- Group 0120 - Non-Powered Wheels and Fastenings
- Group 0199 - Specifications and Special Tools

SECTION 2 - AXLES AND SUSPENSION SYSTEMS

- Group 0201 - Drive Axle Housing and Support
- Group 0210 - Differential or Bevel Drive
- Group 0225 - Input Drive Shafts and U-Joints
- Group 0230 - Non-Powered Wheel Axles
- Group 0250 - Axle Shaft, Bearings, Reduction Gears
- Group 0260 - Hydraulic System
- Group 0299 - Specifications and Special Tools

SECTION 3 - TRANSMISSION

- Group 0325 - Input Drive Shafts and U-Joints
- Group 0341 - Housings and Covers
- Group 0342 - Mounting Parts
- Group 0350 - Gears, Shafts, Bearings, and Power Shift Clutch
- Group 0360 - Hydraulic System
- Group 0399 - Specifications and Special Tools

SECTION 4 - ENGINE

- Group 0400 - Removal and Installation
- Group 0401 - Crankshaft and Main Bearings
- Group 0402 - Camshaft and Valve Actuating Means
- Group 0403 - Connecting Rods and Pistons
- Group 0404 - Cylinder Block
- Group 0407 - Oiling System
- Group 0408 - Ventilating System
- Group 0409 - Cylinder Head and Valves
- Group 0410 - Exhaust Manifold
- Group 0413 - Fuel Injection System
- Group 0414 - Intake Manifold
- Group 0416 - Turbocharger
- Group 0417 - Water Pump
- Group 0418 - Thermostats, Housings, and Water Piping
- Group 0419 - Oil Cooler
- Group 0420 - Fuel Filter
- Group 0421 - Fuel Transfer Pump
- Group 0422 - Starting Motor and Fastenings
- Group 0423 - Alternator and Generator Mounting
- Group 0429 - Fan Drive
- Group 0433 - Flywheel, Housing and Fastenings
- Group 0499 - Specifications and Special Tools

SECTION 5 - ENGINE AUXILIARY SYSTEMS

- Group 0505 - Cold Weather Starting Aids
- Group 0510 - Cooling Systems
- Group 0515 - Speed Controls
- Group 0520 - Intake System
- Group 0530 - External Exhaust System
- Group 0540 - Mounting Frame
- Group 0560 - External Fuel Supply Systems
- Group 0599 - Specifications and Special Tools

SECTION 6 - TORQUE CONVERTER

- Group 0641 - Housing and Cover
- Group 0651 - Turbine, Gears, Shaft, etc.
- Group 0660 - Hydraulic System
- Group 0699 - Specifications and Special Tools

Copyright © 1984
DEERE & COMPANY
Moline, Illinois
All Rights Reserved
Previous Edition
Copyright © 1979 DEERE & COMPANY

SECTION AND GROUP CONTENTS OF THIS MANUAL—Continued

- SECTION 9 - STEERING SYSTEM
Group 0960 - Hydraulic System
Group 0999 - Specifications and Special Tools
- SECTION 10 - SERVICE BRAKES
Group 1011 - Active Elements
Group 1015 - Controls Linkage
Group 1060 - Hydraulic System
Group 1099 - Specifications and Special Tools
- SECTION 11 - PARKING-EMERGENCY BRAKES
Group 1111 - Active Elements
Group 1115 - Controls Linkage
Group 1199 - Specifications and Special Tools
- SECTION 13 - MISCELLANEOUS VEHICLE
Group 1370 - Lubrication Systems
- SECTION 16 - ELECTRICAL SYSTEM
Group 1671 - Batteries, Support and Cables
Group 1672 - Alternator, Regulator and Charging System Wiring
Group 1673 - Lighting System
Group 1674 - Wiring Harness and Switches
Group 1675 - System Controls
Group 1676 - Instruments and Indicators
Group 1699 - Specifications and Special Tools
- SECTION 17 - FRAME, CHASSIS OR SUPPORTING STRUCTURE
Group 1740 - Frame Installation
Group 1746 - Frame Bottom Guards
Group 1799 - Specifications and Special Tools
- SECTION 18 - OPERATOR'S STATION
Group 1810 - Operator Enclosure
Group 1821 - Seat and Seat Belt
Group 1830 - Heating and Air Conditioning
Group 1899 - Specifications and Special Tools
- SECTION 19 - SHEET METAL AND STYLING
Group 1910 - Hood or Engine Enclosure
Group 1913 - Miscellaneous Shields
Group 1921 - Grille and Grille Housing
Group 1927 - Fenders
Group 1999 - Specifications and Special Tools
- SECTION 20 - SAFETY, CONVENIENCE AND MISCELLANEOUS
Group 2004 - Horn
Group 2006 - Cigar Lighter
- SECTION 21 - MAIN HYDRAULIC SYSTEM
Group 2160 - Hydraulic System
Group 2199 - Specifications and Special Tools
- SECTION 35 - SCRAPER AND HAULAGE DEVICE
Group 3501 - Blades or Cutting Edges
Group 3540 - Frames
Group 3560 - Hydraulic System
Group 3599 - Specifications and Special Tools
- SECTION 36 - CONVEYOR AND ELEVATING DEVICE
Group 3612 - Conveyor or Mast
Group 3640 - Conveyor and Elevating Device Frame
Group 3650 - Gear Box
Group 3660 - Hydraulic System
Group 3699 - Specifications and Special Tools
- SECTION 90 - SYSTEM TESTING
Group 9005 - General Information - Seven Basic Steps of Testing and Diagnosis
Group 9010 - Engine
Group 9015 - Electrical
Group 9020 - Power Train
Group 9025 - Hydraulic System (Flow Meter)
Group 9030 - Miscellaneous Components
Group 9031 - Heating and Air Conditioning
Group 9035 - Specifications and Special Tools

MAINTENANCE WITHOUT ACCIDENT WORK SAFELY

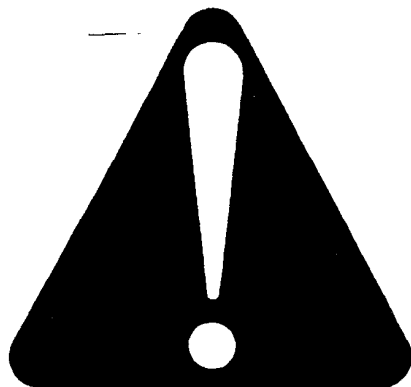

T27999N

 This safety symbol is used for important safety messages. When you see this symbol, follow the safety message to avoid personal injury.

EVERY EMPLOYER HAS A SAFETY PROGRAM. KNOW WHAT IT IS!

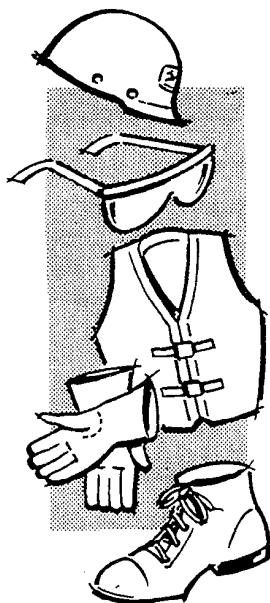

T27501N

See your shop supervisor for specific instructions on a job, and the safety equipment required.

For instance, you may need: Hard hat, safety shoes, safety goggles, heavy gloves, reflector vests, ear protectors, respirator.

RIGHT



WRONG

T27502N

BE ALERT!

Plan ahead — work safely — know how to use a first aid kit and a fire extinguisher — and where to get assistance.

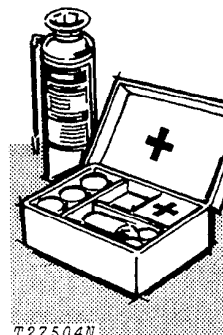

T27504N

Maintenance Area

Make sure the maintenance area has enough ventilation.

Keep the maintenance area **CLEAN AND DRY**. Oily and wet floors are slippery. Greasy rags are a fire hazard. Wet spots are dangerous when working with electrical equipment.

Keep starting aids in a cool, well-ventilated place, out of reach of unauthorized personnel.

MAINTENANCE WITHOUT ACCIDENT

AVOID FIRE HAZARDS

Fuel Is Dangerous!

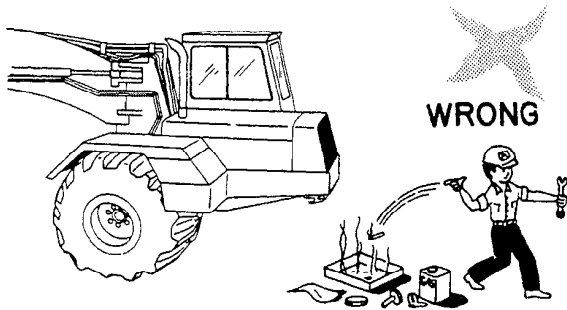

T71141

Do not smoke while putting fuel in the fuel tank.

Do not smoke while working with material that will start on fire easily.

Stop the engine before filling the fuel tank.

Do not use gasoline or diesel fuel for cleaning parts. Use solvents that will not start on fire.

Battery Gas Is Highly Flammable!

When charging batteries, be sure there is enough ventilation.

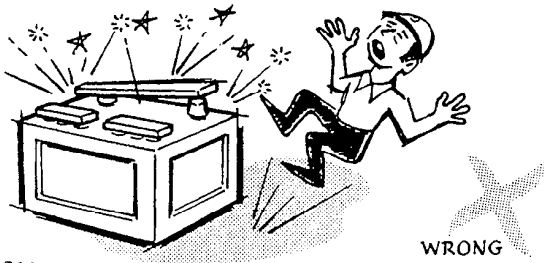

T27506N

Do not check the battery charge by putting metal objects across the terminals.

Do not let sparks or open flame near batteries.

Do not smoke near battery.

Flame Is Not a Flashlight!

NEVER USE OPEN FLAME AROUND THE MACHINE.

KNOW WHERE FIRE EXTINGUISHERS ARE KEPT!

UNDER ALL MAINTENANCE CONDITIONS

Do not work on the equipment unless you are approved to do so. Then be sure you know the safe and correct procedure.

Never work on equipment while it is being operated.

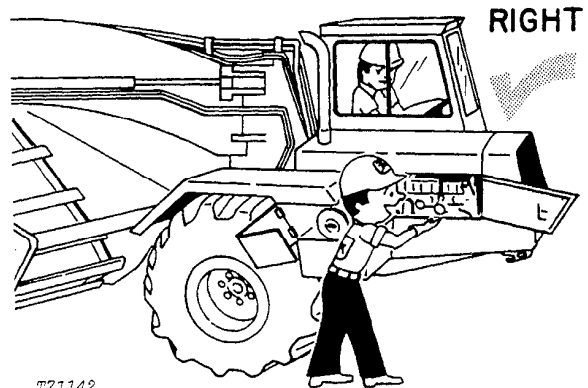

T71142

When the engine is running, avoid working on equipment.

If you must work on the machine with the engine running, ALWAYS USE TWO service technicians. One must be at the controls. The other must be within sight of the operator.

KEEP HANDS AWAY FROM MOVING PARTS

Put a support under all raised equipment.

Never work under a raised bowl.

Lower the bowl to the ground.

If the machine is on a slope, use blocks to hold it in place.

Do not lift heavy parts by yourself. Use hoisting equipment for this.

TAKE CARE! WATCH OUT FOR OTHER PEOPLE IN THE AREA

When drilling, grinding, or hammering metal, wear safety glasses.

BE CAREFUL DURING SERVICE AND REPAIR



Keep ALL equipment free of dirt and oil.

Clean oil, grease, mud, ice or snow from the operator's station, steps and hand rails.

When getting the engine ready for storage, remember that inhibitor changes easily into gas and is dangerous. After adding the inhibitor, seal and tape openings. When you are not using the inhibitor, keep the can tightly closed.

Do not remove the radiator cap unless the engine is cool. First, loosen the cap slowly to the stop. Then release all pressure in the cooling system before removing the cap.

Check the exhaust system regularly for leaks.

Release hydraulic pressure before working on the hydraulic system. Lower the bowl to the ground. Stop the engine. Move the steering wheel until the bowl does not move.

When checking hydraulic pressure, be sure to use the correct test gauge.

Before working on the fuel system, close the fuel shutoff valve.

Before working on the electrical system, or making a major overhaul, disconnect the batteries.

KNOW EQUIPMENT IS READY!

All parts should be in good condition and fastened in place.

CHECK IT OUT!

- ROLL-OVER PROTECTIVE STRUCTURE
- SEAT BELT, ETC.

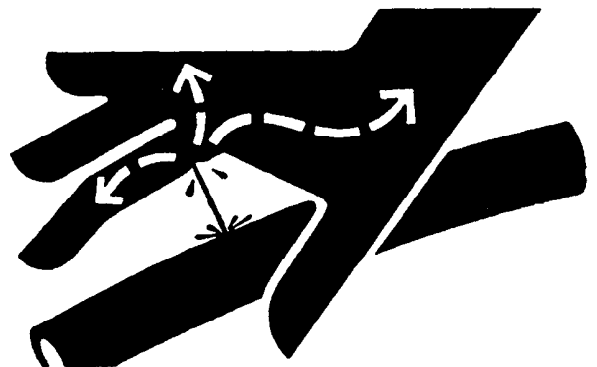
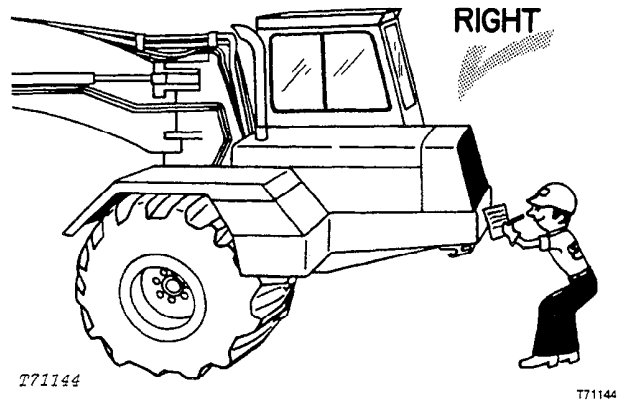

Escaping fluid under pressure can penetrate the skin causing serious injury. Relieve pressure before disconnecting hydraulic or other lines. Tighten all connections before applying pressure. Keep hands and body away from pinholes and nozzles which eject fluids under high pressure. Use a piece of cardboard or paper to search for leaks. Do not use your hand.

If ANY fluid is injected into the skin, it must be surgically removed within a few hours by a doctor familiar with this type injury or gangrene may result.

Avoid possible injury or death from machinery runaway.

Do not start engine by shorting across starter terminals. Machine will start in gear and will move if normal circuitry is bypassed

NEVER start engine while standing on ground. Start engine only from operator's seat, with transmission in neutral, direction selector lever in neutral, and park brake applied.

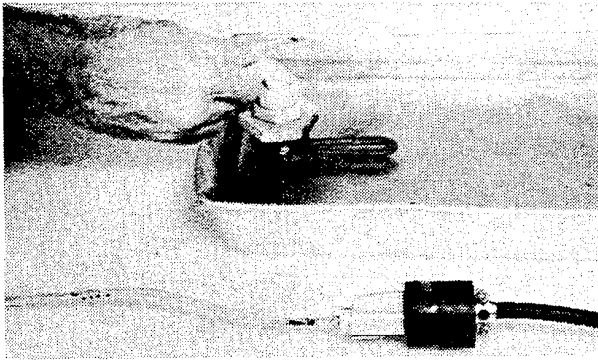

T87098

Test coolant heater in liquid only.

Use a heavy-duty grounded cord to connect coolant heater to electrical power.

Do not plug into electrical power unless heating element is immersed in coolant. Sheath could burst and result in personal injury.

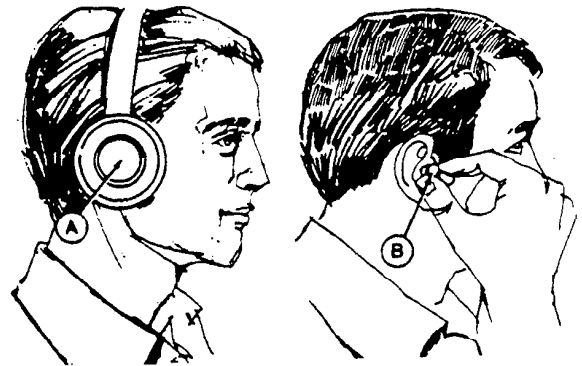

X7662

Prolonged exposure to loud noise can cause impairment or loss of hearing. Wear a suitable hearing protective device such as earmuffs (A) or earplugs (B) to protect against objectionable or uncomfortable loud noise.

If your machine is equipped with a starting fluid starting aid, remember starting fluid is highly flammable. **DO NOT** incinerate or puncture a starting fluid container. **DO NOT** store a starting fluid container in a high-temperature area.



T84926

If your machine has a roll-over protective structure, **USE A SEAT BELT.**

If your machine does not have a roll-over protective structure, **DO NOT USE A SEAT BELT.**

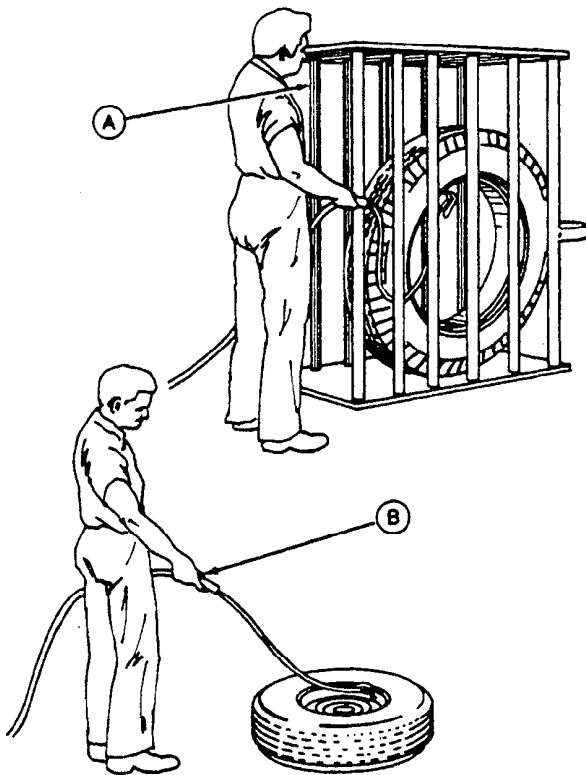

Failure to follow proper procedures when mounting a tire on a wheel or rim can produce an explosion which may result in serious injury or death. Do not attempt to mount a tire unless you have the proper equipment and experience to perform the job. Have it done by your John Deere dealer or a qualified tire repair service.

Detailed tire mounting instructions, including necessary safety precautions, are contained in John Deere Fundamentals of Service (FOS) Manual 55, Tires and Tracks, available through your John Deere dealer. Such information also available from the Rubber Manufacturers Association and from tire manufacturers.

A—Use a Safety Cage if Available
B—DO NOT Stand Over Tire. Use a Clip-On Chuck and Extension Hose.

TS0123

Group III GENERAL SPECIFICATIONS

(Specifications and design subject to change without notice. Wherever applicable, specifications are in accordance with ICED and SAE Standards. Except where otherwise noted, these specifications are based on a unit equipped with 26.5-25, 24 ply rating tires, ROPS canopy, full fuel tank, 175 lb. (80 kg) operator, and all standard equipment.)

Capacity (SAE heaped):

Volume 16 cu. yd. (12.23 m³)
Total weight of payload @ 2500 lb./yd.³
(1483 kg/m³) 40,000 lb. (18 144 kg)

Power (@ 2100 engine rpm):

	SAE	DIN
Gross	270 hp (201 kW*)	
Net	250 hp (186 kW)	253.5 PS

Net engine flywheel power is for an engine equipped with fan, air cleaner, water pump, lubricating oil pump, fuel pump, alternator, and muffler. Gross engine power is without fan. Flywheel power ratings are under SAE standard conditions of 500 ft. altitude and 85°F temperature and DIN 70 020 standard conditions of 760 mm Hg barometer (sea level) and 20°C temperature. Engine maintains rated horsepower up to 7500 feet (2 290 m) altitude.

**In the International System of Units (SI), power is expressed in kilowatts (kW).*

Engine: John Deere turbocharged and intercooled diesel, 6-cylinder, 4-stroke cycle

Bore and stroke 5.12x5 in. (130x127 mm)
Piston displacement 619 cu. in. (10 144 cm³)
Compression ratio 15.2 to 1
Maximum torque @
1400 rpm 813 lb-ft (1102 N·m) (112.4 kg-m)
NAACC or AMA (U.S. Tax) horsepower 62.9
Main bearings 7
Lubrication Pressure system w/full-flow filter
Cooling Pressurized w/thermostat and fixed bypass
Fan Suction
Air cleaner w/restriction indicator Dry
Electrical system 24 volt w/alternator
Batteries (two 12 volt) Reserve capacity:
310 minutes

Transmission: Planetary Power-Shift, 6 speeds forward, 1 reverse. Micro-processor controlled, fully automatic shift with complete modulation

Torque Converter: Two phase, single stage with a 2.84 to 1 multiplication ratio, free-wheeling stator lock-up clutch and automatic control

Differential Lock Foot-operated, hydraulically actuated

Drive Axle . . Differential drive; over-all ratio 22.22 to 1; planetary final drives with 4.4 gpm (0.28 L/s) for lubrication and differential lock actuation

Brakes: Hydraulic, power actuated. An accumulator provides several brake applications after engine is stopped.

Tractor Wet-disk between differential and planetaries. No adjustment needed.

Scraper . . Expanding shoe, self-adjusting in wheels.

Parking Manually controlled, mechanical, on axle input shaft.

Power Steering: Position-responsive
Articulated frame hydraulically actuated by dual cylinders.

Turning circle
(180 deg. turn) 32 ft. 9.9 in. (10.0 m)

Articulation 180 deg.

Tractor Oscillation (total) 40 deg.

Hydraulic System:

Main tractor system: Closed-center
System pressure 2350 psi (16 203 kPa)
(165.2 kg/cm²)

Operates steering, brakes, and all scraper functions except elevator drive.

Main pump . . . Variable displacement, constant pressure; delivers 63 gpm (3.97 L/s) @ 2100 engine rpm.

Main charge pump delivers 20.3 gpm (1.28 L/s) @ 2100 engine rpm.

Elevator system . . . Engine-driven, 5.43 cu. in. (89 cm³) variable displacement, reversible hydrostatic pump delivers 53.5 gpm (3.38 L/s) @ 2100 engine rpm.

System pressure 5000 psi (34 475 kPa)
(351 kg/cm²)

Filtration . . . All systems are protected by replaceable filters.

Main hydraulic system 10-micron filters

Elevator system 10-micron filters

Transmission 10-micron filters

Hydraulic Cylinders:	Bore	Stroke
Lift (2)	5 in. (127 mm)	20 in. (508 mm)
Sliding floor (1)	5.25 in. (133 mm)	38.8 in. (986 mm)
Ejector gate (2)	3 in. (76 mm)	49.0 in. (1.24 m)
Steering (2)	4 in. (102 mm)	25.9 in. (658 mm)
Piston rods	Ground, heat-treated, chrome-plated, polished	
Lift and steering cylinders	2 in. (51 mm) dia.	
Sliding floor cylinder	2.5 in. (64 mm) dia.	
Ejector gate cylinders	1.75 in. (44 mm) dia.	

Elevator: Reversible, hydrostatic drive with heavy-duty planetary reduction
 Number of flights 23
 Spacing of flights 12.52 in. (318 mm)
 Width of flights 6 ft. 6 in. (1.98 m)
 Speed (@ 2100 engine rpm) . . 0-240 fpm (73 m/min)
 Length (top to bottom) 12 ft. (3.66 m)

Bowl: . . . Heavy-gauge steel with reinforcing and box construction. Sliding floor rides on heat-treated rails. Cutting edge retracts. Independent axles are vertically adjustable.

Cutting Edge: . . . 8 ft. 9.9 in. (2.69 m) wide; 3 sections, reversible and replaceable, high-carbon steel. Each section is adjustable vertically 2 in. (51 mm).
 Center section . . . 1x13x77.9 in. (25x330x1979 mm)
 End sections 1x13x14 in. (25x330x356 mm)

Tires:
 26.5-29, steel-cord radials
 26.5-25, 24 ply rating, E2
 26.5-29, 26 ply rating, E3
 26.5-29, steel-cord radials

Capacities:	U.S.	IMP.	Liters
Cooling system	15 gal.	12.5 gal.	56.8
Fuel tank	113 gal.	94.4 gal.	429
Engine lubrication, including filter	31 qt.	25.8 qt.	29.3
Transmission case and filter	19 gal.	15.8 gal.	71.9
Differential case	7.5 gal.	6.2 gal.	28.4
Hydraulic reservoir	24 gal.	20.0 gal.	90.8
Elevator gear case	8 qt.	6.7 qt.	7.6

Weight Distribution:	lb.	kg
Empty: Drive axle	32,050	14 538
Scraper axle	17,139	7 774
Total	49,189	22 312
Loaded: Drive axle	44,400	20 140
Scraper axle	44,789	20 316
Total	89,189	40 456

JD862 SCRAPER DIMENSIONS

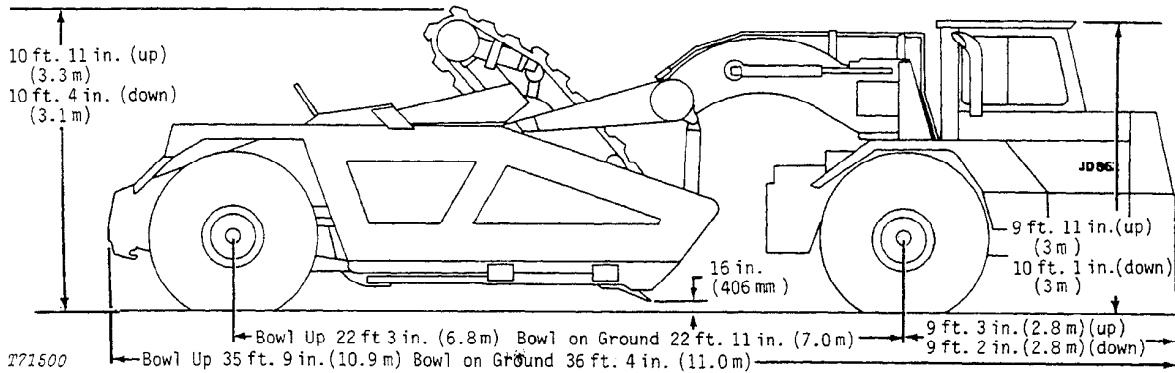
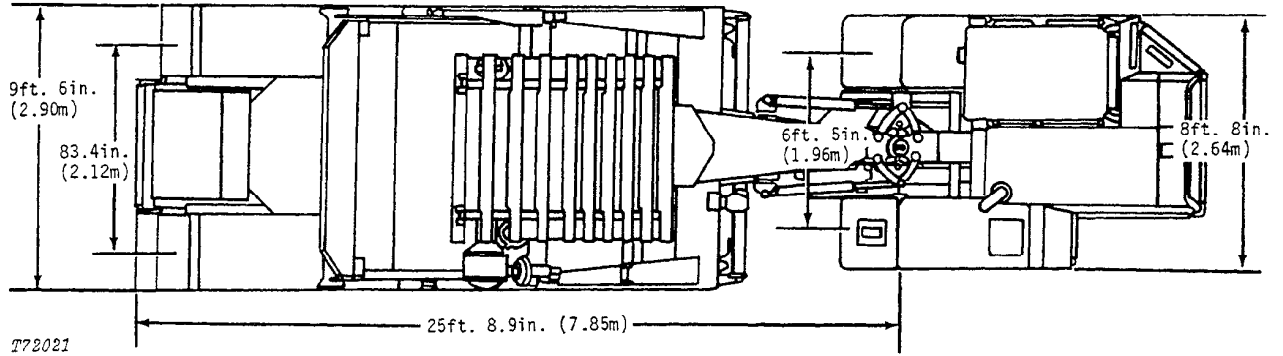

BUY NOW

**Then Instant Download
the Complete Manual
Thank you very much!**