

# **21C, 21S, 21HC and 45BP Hand Held Products**

## **TECHNICAL MANUAL**

**John Deere  
Lawn & Grounds Care Division  
TM1524 (April 95)**

**Safety**



**Specifications and  
Information**



**Engine**



**Electrical**



**Power Train**





## HANDLE FLUIDS SAFELY-AVOID FIRES

- BE PREPARED FOR EMERGENCIES



TS291

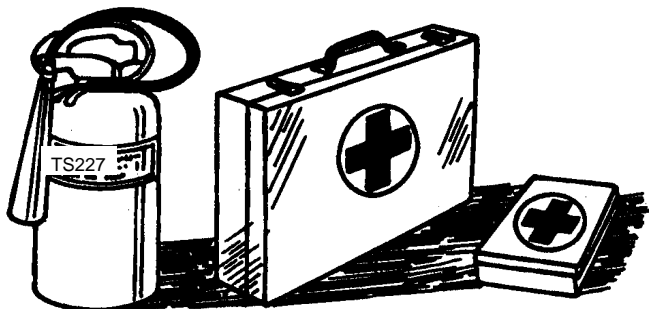

When you work around fuel, DO NOT smoke or work near heaters or other fire hazards.

Store flammable fluids away from fire hazards. DO NOT incinerate or puncture pressurized containers.

Make sure machine is clean of trash, grease, and debris.

DO NOT store oily rags; they can ignite and burn spontaneously.

### Be prepared if a fire starts:

- Keep a first aid kit and fire extinguisher handy.
- Keep emergency numbers for doctors, ambulance service, hospital, and fire department near your telephone.

## HANDLE CHEMICAL PRODUCTS SAFELY

- Follow safe procedures and use recommended equipment..



TS1132

Direct exposure to hazardous chemicals can cause serious injury. Potentially hazardous chemicals used with John Deere equipment include such items as lubricants, coolants, paints, and adhesives.

A Material Safety Data Sheet (MSDS) provides specific details on chemical products: physical and health hazards, safety procedures, and emergency response techniques. Check the MSDS before you start any job using a hazardous chemical. That way you will know exactly what the risks are and how to do the job safely. Then follow procedures and recommended equipment.

- DISPOSE OF WASTE PROPERLY

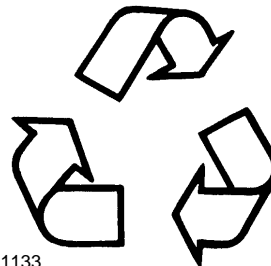

TS1133

Improperly disposing of waste can threaten the environment and ecology. Potentially harmful waste used with John Deere equipment include such items as oil, fuel, coolant, brake fluid, filters, and batteries. Use leakproof containers when draining fluids. DO NOT use food or beverage containers that may mislead someone into drinking from them. DO NOT pour waste onto the ground, down a drain, or into any water source. Inquire on the proper way to recycle or dispose of waste from your local environmental or recycling center, or from your John Deere dealer.

## USE SAFE SERVICE PROCEDURES

### • WEAR PROTECTIVE CLOTHING

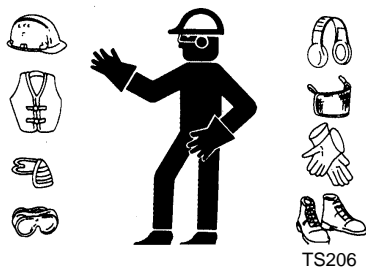

Wear close fitting clothing and safety equipment appropriate to the job.

Prolonged exposure to loud noise can cause impairment or loss of hearing. Wear a suitable hearing protective device such as earmuffs or earplugs to protect against objectionable or uncomfortable loud noises.

Operating equipment safely requires the full attention of the operator. **DO NOT** wear radio or music headphones while operating machine.

Tie long hair behind your head. **DO NOT** wear a necktie, scarf, loose clothing, or necklace when you work near machine tools or moving parts. If these items were to get caught, severe injury could result.

Remove rings and other jewelry to prevent electrical shorts and entanglement in moving parts.

### • USE PROPER TOOLS

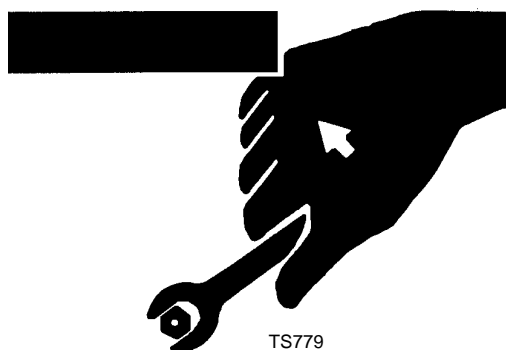

Use tools appropriate to the work. Makeshift tools and procedures can create safety hazards. Use power tools only to loosen threaded parts and fasteners. For loosening and tightening hardware, use the correct size tools. **DO NOT** use U.S. measurement tools on metric fasteners or vice versa. Avoid bodily injury caused by slipping wrenches. Use only service parts meeting John Deere specifications.

### • WORK IN CLEAN AREA

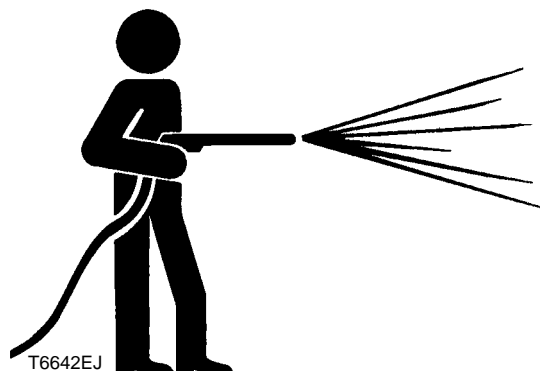

#### Before starting a job

1. Clean work area and machine;
2. Make sure you have all necessary tools to do your job;
3. Have the right parts on hand;
4. Read all instructions thoroughly; **DO NOT** attempt shortcuts;

### • ILLUMINATE WORK AREA SAFELY

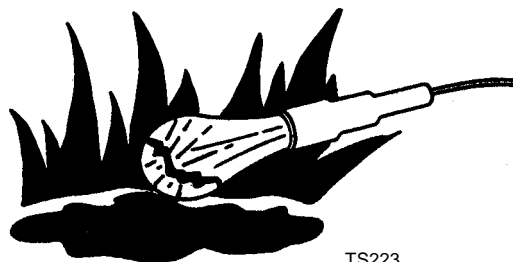

Illuminate your work area adequately but safely. Use a portable safety light for working inside or under the machine. Make sure the bulb is enclosed by a wire cage. The hot filament of an accidentally broken bulb can ignite spilled fuel or oil.

### • WORK IN VENTILATED AREA

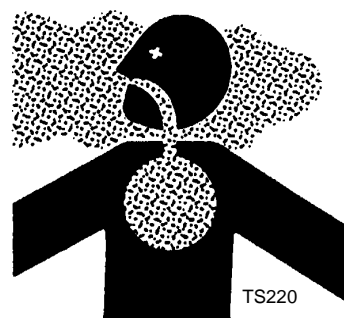

Engine exhaust fumes can cause sickness or death. If it is necessary to run an engine in an enclosed area, remove the exhaust fumes from the area with an exhaust pipe extension.

If you **DO NOT** have an exhaust pipe extension, open the doors and get outside air into the area.



## • AVOID HARMFUL ASBESTOS DUST

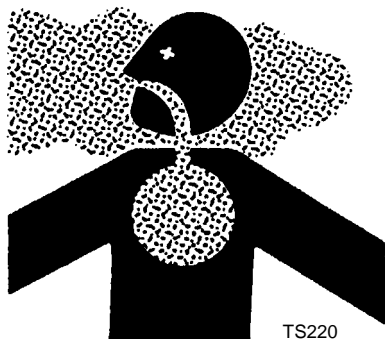

TS220

Avoid breathing dust that may be generated when handling components containing asbestos fibers. Inhaled asbestos fibers may cause lung cancer.

Components that may contain asbestos fibers are brake pads, brake band and lining assemblies, clutch plates, and some gaskets. The asbestos used in these components is usually found in a resin or sealed in some way. Normal handling is not hazardous as long as airborne dust containing asbestos is not generated.

Avoid creating dust. Never use compressed air for cleaning. Avoid brushing or grinding material containing asbestos. When servicing, wear an approved respirator. A special vacuum cleaner is recommended to clean asbestos. If not available, apply a mist of oil or water on the material containing asbestos.

Keep bystanders away from the area.

## REPLACE SAFETY SIGNS



TS201

Replace missing or damaged safety signs. See the machine operator's manual for correct safety sign placement.

## OPERATE HEDGE CLIPPER SAFELY



TY14128

Keep people and pets out of the area where you are using the hedge clipper.

DO NOT let children operate hand held equipment.

DO NOT point hand held cutting blade in the direction of people or pets.

Keep your hair from being drawn into hand held equipment.

DO NOT touch cylinder or muffler assembly when you handle hand held equipment.

Start hand held equipment on the ground.

### Before you service, adjust, clean, fuel, or inspect hand held equipment:

- Stop engine;
- Wait for engine to cool;
- Keep hand held equipment engines clean; remove grass, leaves, oil, and dirt before you start;
- Unauthorized modifications to the machine may impair the function and/or safety and affect machine life and warranty;
- DO NOT run engine in an enclosed area. Exhaust fumes contain carbon monoxide, an odorless and deadly poison;
- Keep machine hand grips clean and dry;
- When operating machine, hold firmly with both hands. Maintain proper footing and balance. DO NOT reach or lean too far to make a cut;
- Move machine away from your body. DO NOT draw blades toward you;
- If cutting blade or blades are cracked, replace immediately and;
- DO NOT attempt to fill fuel tank, make adjustments, or clean hand held equipment while engine is running or hot;

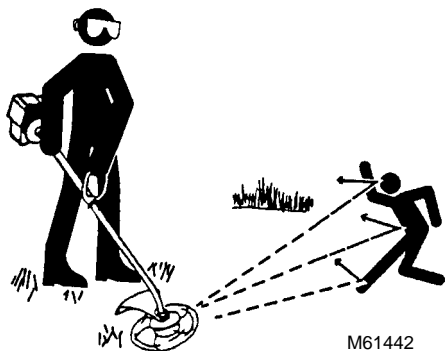
**INSPECT CUTTING AREA**

Remove all debris (string, wire, or cords) which might clog cutting head.

Remove objects (bottles, cans, or sticks) that might be thrown by clipper, trimmer/edger or cutter.

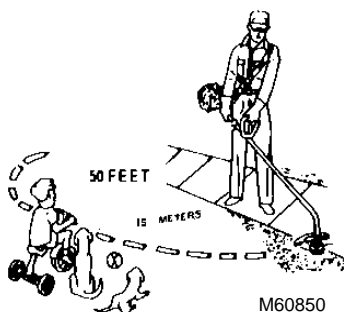
**OPERATE TRIMMERS SAFELY**

Keep people and pets out of the area where you are using the machine.

Unauthorized modifications to the machine may impair the function and/or safety and affect machine life.

DO NOT run engine in an enclosed area. Exhaust fumes contain carbon monoxide, an odorless and deadly poison.

Keep machine hand grips clean and dry.

When operating machine, hold firmly with both hands. Keep proper footing and balance.

Move machine away from your body. DO NOT draw blades or cutting head toward you. DO NOT reach to make a cut.

When operating hand held equipment with optional blade installed, always use shoulder harness and grip handlebars securely.

Use metal shield when using blades on hand held equipment.

Take precautions to avoid "kickback".

If cutting blade or blades are cracked, replace immediately.

DO NOT attempt to fill fuel tank, make adjustments, or clean while engine is running.

**OPERATE BLOWER SAFELY**

Keep people and pets out of the area where you are using the hand held equipment.

DO NOT let children operate hand held equipment.

DO NOT point blower air pipes in the direction of people or pets.

Keep your hair from being drawn into hand held equipment.

DO NOT touch cylinder or muffler assembly when you handle hand held equipment.

Start hand held equipment on the ground, not on operator's back.

Move air pipe or fan intake to avoid air flow restriction.

Before you service, adjust, clean, fuel, or inspect hand held equipment:

Stop engine.

Wait for engine to cool.

Keep hand held equipment engines clean. Remove grass, leaves, oil, and dirt before you start engine.

**LIVE WITH SAFETY**

TS231



Before returning machine to customer, make sure machine is functioning properly, especially the safety systems. Keep all installed guards and shields.

# SAFETY

---



NOTES

# CONTENTS

Page



## SPECIFICATIONS & INFORMATION

**UNIFIED INCH TORQUE VALUES** ..... 5

**METRIC TORQUE VALUES** ..... 6

**FUEL SPECIFICATIONS** ..... 7

    FUEL STORAGE ..... 7

**MIXING FUEL** ..... 8

**LUBRICANTS** ..... 9

    GREASE ..... 9

    HEDGE CLIPPER BLADE OIL ..... 9

**TRIMMERS—21C/21S** ..... 10

**HEDGE CLIPPER—21HC** ..... 11

**BACKPACK BLOWER—45BP** ..... 12

**SERIAL NUMBER LOCATION** ..... 13

    TRIMMERS—21C, 21S ..... 13

    HEDGECLIPPER—21HC ..... 13











    BLOWER—45BP ..... 13





UNIFIED INCH TORQUE VALUES



SAE Grade and Head Markings	1 or 2 <sup>b</sup> No Marks 	5  5.1  5.2 	8  8.2 
	2 No Marks 	5  	8  

TS1162

SIZE	Grade 1		Grade 2 <sup>b</sup>		Grade 5, 5.1 or 5.2		Grade 8 or 8.2	
	Lubricated <sup>a</sup>	Dry <sup>a</sup>	Lubricated <sup>a</sup>	Dry <sup>a</sup>	Lubricated <sup>a</sup>	Dry <sup>a</sup>	Lubricated <sup>a</sup>	Dry <sup>a</sup>
	Nm	lb-ft	Nm	lb-ft	Nm	lb-ft	Nm	lb-ft
1/4	3.7	2.8	4.7	3.5	6	4.5	7.5	5.5
5/16	7.7	5.5	10	7	12	9	15	11
3/8	14	10	17	13	22	16	27	20
7/16	22	16	28	20	35	26	44	32
1/2	33	25	42	31	53	39	67	50
9/16	48	36	60	45	75	56	95	70
5/8	67	50	85	62	105	78	135	100
3/4	120	87	150	110	190	140	240	175
7/8	190	140	240	175	190	140	240	175
1	290	210	360	270	290	210	360	270
1-1/8	470	300	510	375	470	300	510	375
1-1/4	570	425	725	530	570	425	725	530
1-3/8	750	550	950	700	750	550	950	700
1-1/2	1000	725	1250	925	990	725	1250	930

DO NOT use these values if a different torque value or tightening procedure is given for a specific application. Torque values listed are for general use only. Check tightness of fasteners periodically.

Shear bolts are designed to fail under predetermined loads. Always replace shear bolts with identical grade.

Fasteners should be replaced with the same or higher grade. If higher grade fasteners are used, these should only be tightened to the strength of the original. Make sure fasteners threads are clean and that you properly start thread engagement, this will prevent them from failing when tightening. Tighten plastic insert or crimped steel-type lock nuts to approximately 50 percent of the dry torque values shown in the chart. Torque values are to be applied to the nut, not to the

bolt head.

Tighten toothed or serrated-type lock nuts to the full torque value.

<sup>a</sup> "Lubricated" means coated with a lubricant such as engine oil, or fasteners with phosphate and oil coatings. "Dry" means plain or zinc plated without any lubrication

<sup>b</sup> Grade 2 applies for hex cap screws (not hex bolts) up to 152 mm (6-in.) long. Grade 1 applies for hex cap screws over 152 mm (6-in.) long, and for all other types of bolts and screws of any length.

METRIC TORQUE VALUES



Property Class and Head Markings	4.8	8.8	9.8	10.9	12.9
Property Class and Nut Markings	5	10	10	12	

Ts1163

SIZE	Class 4.8		Class 8.8 or 9.8				Class 10.9				Class 12.9					
	Lubricated <sup>a</sup>		Dry <sup>a</sup>		Lubricated <sup>a</sup>		Dry <sup>a</sup>		Lubricated <sup>a</sup>		Dry <sup>a</sup>		Lubricated <sup>a</sup>		Dry <sup>a</sup>	
	Nm	lb-ft	Nm	lb-ft	Nm	lb-ft	Nm	lb-ft	Nm	lb-ft	Nm	lb-ft	Nm	lb-ft	Nm	lb-ft
M6	48	3.5	6	4.5	9	6.5	11	8.5	13	9.5	17	12	15	11.5	19	14.5
M8	12	8.5	15	11	22	16	28	20	32	24	40	30	37	28	47	35
M10	23	17	29	21	43	32	55	40	63	47	80	60	75	55	95	70
M12	40	29	50	37	75	55	95	70	110	80	140	105	130	95	165	120
M14	63	47	80	60	120	88	150	110	175	130	225	165	205	150	260	109
M16	100	73	125	92	190	140	240	175	275	200	350	225	320	240	400	300
M18	135	100	175	125	260	195	330	250	375	275	475	350	440	325	560	410
M20	190	140	240	180	375	275	475	350	530	400	675	500	625	460	800	580
M22	260	190	330	250	510	375	650	475	725	540	925	675	850	625	1075	800
M24	330	250	425	310	650	475	825	600	925	675	1150	850	1075	800	1350	1000
M27	490	360	625	450	950	700	1200	875	1350	1000	1700	1250	1600	1150	2000	1500
M30	675	490	850	625	1300	950	1650	1200	1850	1350	2300	1700	2150	1600	2700	2000
M33	900	675	1150	850	1750	1300	2200	1650	2500	1850	3150	2350	2900	2150	3700	2750
M36	1150	850	1450	1075	2250	1650	2850	2100	3200	2350	4050	3000	3750	2750	4750	3500

DO NOT use these values if a different torque value or tightening procedure is given for a specific application. Torque values listed are for general use only. Check tightness of fasteners periodically.

Shear bolts are designed to fail under predetermined loads. Always replace shear bolts with identical grade.

Fasteners should be replaced with the same or higher grade. If higher grade fasteners are used, these should only be tightened to the strength of the original. Make sure fasteners threads are clean and that you properly start thread engagement. This will prevent them from failing when tightening.

Tighten plastic insert or crimped steel-type lock nuts to approximately 50 percent of the dry torque values shown in the chart. Torque values are to be applied to the nut, not to the bolt head. Tighten toothed or serrated-type lock nuts to the full torque value.

<sup>a</sup> "Lubricated" means coated with a lubricant such as engine oil, or fasteners with phosphate and oil coatings. "Dry" means plain or zinc plated without any lubrication.

<sup>b</sup> Grade 2 applies for hex cap screws (not hex bolts) up to 152 mm (6-in.) long. Grade 1 applies for hex cap screws over 152 mm (6-in.) long, and for all other types of bolts and screws of any length.

## FUEL SPECIFICATIONS

### C CAUTION

Handle fuel with care, it is highly flammable.

**DO NOT** refuel machine:

- Indoors. Always fill fuel tank outdoors.
- While you smoke.
- When machine is near an open flame or sparks.
- When engine is running- always STOP engine.
- When engine is hot- allow it to cool completely.

Help prevent fires:

- Fill fuel tank only to bottom of filler neck.
- Clean oil, grease and dirt from machine.
- Clean up spilled fuel immediately.
- Do not store machine with fuel in tank in a building where fumes may reach an open flame or spark.

To prevent fire and explosion caused by static electric discharge while you fill tank:

- Use approved, non-metal fuel container.
- When using a funnel, **MAKE SURE** it is **PLASTIC**.
- Avoid using a funnel which has a metal screen or filter.



**IMPORTANT:** To avoid engine damage:

- Mix oil with gasoline in the correct ratio. (See MIXING FUEL on next page)
- Use only clean oil and fuel
- Use clean approved containers and funnels.
- Store oil and fuel in an area protected from dust, moisture and other contamination.

Unleaded fuel is recommended because it burns cleaner and leaves less unburned deposits in engine combustion chamber. Unleaded gasoline with an anti-knock index of 87 or higher may be used. Use of gasohol is acceptable as long as the ethyl alcohol blend does not exceed 11 percent. Unleaded gasohol is preferred over leaded gasohol.

## FUEL STORAGE

**IMPORTANT:** Keep all dirt, scale, water or other foreign material out of fuel.

Keep fuel in a clean container in a protected cabinet or area. Water and sediment must be separated before fuel gets to the engine. If possible, install a water separator at the storage tank outlet. Do not use deicers or depend on fuel filters to remove water from fuel.

**MIXING FUEL**



**IMPORTANT:** Use leaded or unleaded gasoline with a minimum octane rating of 87. Do not use ethyl gasoline, gasohol, or other alcohol blended fuels if they exceed 11 percent blend ratio.

- When using oil meeting BIA certification for TC-W service, use 32:1 ratio fuel-oil mixture.
- When using John Deere 2-Cycle Engine Oil, use a 50:1 ratio fuel-oil mixture.

<b>FUEL MIX CHART (32:1 Mixture)</b>					
U.S.		IMPERIAL		S.I. (Metric)	
Gas	Oil To Be Added	Gas	Oil To Be Added	Petrol	Oil To Be Added
1 gal	4 oz	1 gal	5 oz	4 L	125 mL
2 gal	8 oz	2 gal	10 oz	8 L	250 mL
2-1/2 gal	10 oz	2-1/2 gal	12.5 oz	10 L	313 mL
3 gal	12 oz	3 gal	15 oz	12 L	375 mL
4 gal	16 oz	4 gal	20 oz	16 L	500 mL
5 gal	20 oz	5 gal	25 oz	20 L	625 mL
6 gal	24 oz	6 gal	30 oz	24 L	750 mL

<b>FUEL MIX CHART (50:1 Mixture)</b>					
U.S.		IMPERIAL		S.I. (Metric)	
Gas	Oil To Be Added	Gas	Oil To Be Added	Petrol	Oil To Be Added
1 gal	2.5 oz	1 gal	3.2 oz	4 L	80 mL
2 gal	5.0 oz	2 gal	6.4 oz	8 L	160 mL
2-1/2 gal	6.4 oz	2-1/2 gal	8.0 oz	10 L	200 mL
3 gal	7.5 oz	3 gal	9.6 oz	12 L	240 mL
4 gal	10.0 oz	4 gal	12.8 oz	16 L	320 mL
5 gal	12.5 oz	5 gal	16.0 oz	20 L	400 mL
6 gal	15.0 oz	6 gal	19.2 oz	24 L	480 mL

**Mixing Instructions:**

*NOTE: Use only oils recommended in this section. DO NOT mix fuel in engine fuel tank.*

1. Pour 1/2 of the gasoline into a clean safe container.
2. Add oil to gas and mix.
3. Add remaining gasoline, remix and fill the fuel tank.
4. Install fuel tank cap and wipe spilled fuel from container and area.

**LUBRICANTS**

**GREASE**

Use grease based on the expected ambient air temperature range during the service interval.

The following greases are preferred:

- John Deere MOLY HIGH TEMPERATURE EP GREASE
- John Deere HIGH TEMPERATURE EP GREASE
- John Deere GREASE-GARD™

Other greases may be used if they meet one of the following:

- SAE Multipurpose EP Grease with a maximum of 5% molybdenum disulfide.
- SAE Multipurpose EP Grease

Greases meeting Military Specification MIL-G-10924F may be used as arctic grease.

**HEDGE CLIPPER BLADE OIL**

John Deere TORQ-GARD SUPREME® or John Deere PLUS 4® engine oil is recommended for lubricating the cutting blades. If other oils are used, they must be premium quality engine oils meeting performance requirements of:

—API Service Classification SD, SE or SF.

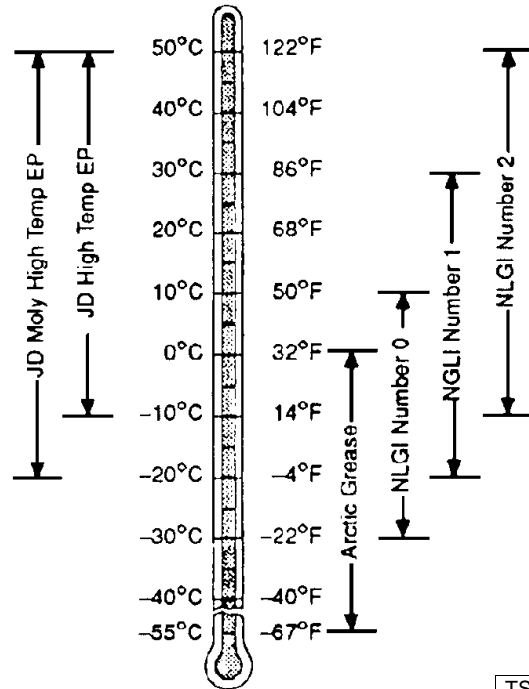

TS1417



**TRIMMERS—21C/21S**



**ENGINE**

Type.....	2 Cycle, Air Cooled
Displacement .....	21.2 cc (1.294 cu. in.)
Bore.....	32.2 mm (1.27 in.)
Stroke .....	26.0 mm (1.024 in.)
Horsepower.....	.66 kW (.88 hp.)
Compression Ratio .....	6.5:1
Compression Pressure .....	833 kPa (125 PSI)
Carburetor.....	Diaphragm type w/ starting primer
Exhaust System .....	Spark arrestor type
Fuel/Oil Ratio	
John Deere 2-cycle Oil .....	50:1
BIA Cert. TC-W service.....	32:1
Fuel Type.....	Regular or Unleaded
Fuel Tank Capacity .....	0.4 L (13.5 fl. oz.)
Starter.....	Auto-rewind
Low Idle Speed .....	2500/3000 RPM
High Idle Speed.....	9000 RPM
Clutch Engagement Speed.....	3500 RPM

**ELECTRICAL**

Ignition.....	Flywheel Magneto, CDI System
Spark Plug.....	John Deere AM54611 (Champion CJ-7Y) or TY15207 (NGK BPM7A)
Spark Plug Gap.....	0.6—0.7 mm (0.024—0.028 in.)
Spark Plug Torque.....	15.0—17.0 N•m (130—150 lb-in.)
CDI Module Air Gap .....	0.3—0.4 mm (0.012—0.016 in.)
Secondary Coil Resistance.....	1500—2500 ohms

**POWER TRAIN**

Drive	
Clutch Type .....	Auto-centrifugal
Drive Shaft.....	4-layer flexible steel cable
Shaft Length .....	[21C] 1422 mm (56 in.)—[21S] 1524 mm (60 in.)
Rotation (Viewed from top) .....	[21C] Clockwise—[21S] Counterclockwise
Gear Case Reduction .....	[21S only] 1:1.4
Cutter Head	
Line Diameter .....	[21C] 2 mm (.080 in.)—[21S] 2.4 mm (.095 in.)
Exits.....	Dual
Line Advance.....	Semi-auto
Cutting Width.....	[21C] 406 mm (16 in.)—[21S] 432 mm (17 in.)

## HEDGE CLIPPER—21HC

### ENGINE

Type	2 Cycle, Air Cooled
Displacement	21.2 cc (1.294 cu. in.)
Bore	32.2 mm (1.27 in.)
Stroke	26.0 mm (1.024 in.)
Horsepower	.66 kW (.88 hp.)
Compression Ratio	6.5:1
Compression Pressure	758 kPa (110 PSI)
Carburetor	Diaphragm type w/ starting primer
Exhaust System	Spark arrester type
Fuel/Oil Ratio	
John Deere 2-cycle Oil	50:1
BIA Cert. TC-W service	32:1
Fuel Type	Regular or Unleaded
Fuel Tank Capacity	500 cc (16.9 fl. oz.)
Starter	Auto-rewind
Low Idle Speed	2500/3000 RPM
High Idle Speed	6000/8000 RPM
Clutch Engagement Speed	3700 RPM



### ELECTRICAL

Ignition	Flywheel Magneto, CDI System
Spark Plug	John Deere AM54611 (Champion CJ-7Y)
Spark Plug Gap	0.6—0.7 mm (0.024—0.028 in.)
Spark Plug Torque	15.0—17.0 N•m (130—150 lb-in.)
CDI Module Air Gap	0.3—0.4 mm (0.012—0.016 in.)
Secondary Coil Resistance	1500—2500 ohms

### POWER TRAIN

Gear Case	
Reduction Ratio	1:5.13
Drum Gear	.8 Teeth
Drive Gear	.41 Teeth
Lubrication	John Deere Moly High Temp Grease TY6333
Capacity	70g (2.5 oz.)
Cutter Blades	
Cutting Action	Reciprocating Dual-Action Type
Length	750 mm (29.5 in.)
Blade Knives	
Type	Double-edged
Number of Knives	21 per blade
Length	23 mm (0.906 in.)
Thickness	3 mm (0.118 in.)
Pitch	35 mm (1.378 in.)
Cutting Direction	Single-forward Sweep only
Lubrication	Engine oil every 4 hours



**BACKPACK BLOWER—45BP**



**ENGINE**

Type.....	2 Cycle, Air Cooled
Displacement .....	44 cc (2.69 cu. in.)
Bore.....	40.0 mm (1.58 in.)
Stroke .....	35.0 mm (1.38 in.)
Horsepower.....	@ 7000 RPM 1.5 kW (2.0 hp.)
Compression Ratio .....	7.0:1
Compression Pressure .....	758 kPa (110 PSI)
Carburetor.....	Diaphragm type w/ starting primer
Exhaust System .....	Spark arrester type
Fuel/Oil Ratio	
John Deere 2-cycle Oil .....	50:1
BIA Cert. TC-W service.....	32:1
Fuel Type.....	Regular or Unleaded
Fuel Tank Capacity .....	67.6 fl. oz. (1.9 L.)
Starter.....	Auto-rewind
Low Idle Speed .....	2500/2800 RPM
High Idle Speed.....	6400/6600 RPM

**ELECTRICAL**

Ignition.....	Flywheel Magneto, CDI System
Spark Plug.....	John Deere M122747 (NGK BPM7Y)
Spark Plug Gap.....	0.6—0.7 mm (0.024—0.028 in.)
Spark Plug Torque.....	15.0—17.0 N•m (130—150 lb-in.)
CDI Module Air Gap .....	0.3—0.4 mm (0.012—0.016 in.)
Secondary Coil Resistance.....	1000—1500 ohms

**POWER TRAIN**

Blower Type.....	Direct-drive
Maximum Air Speed .....	180 MPH (288 km/h)
Maximum Air Volume .....	@ 7000 RPM 371 cu. ft./min. (10.5 m <sup>3</sup> /min.)

**SERIAL NUMBER LOCATION**

When ordering parts or submitting a warranty claim, it is **IMPORTANT** that you include the machine product identification number and the model number.

The locations of the product identification numbers are shown.

**TRIMMERS—21C, 21S**

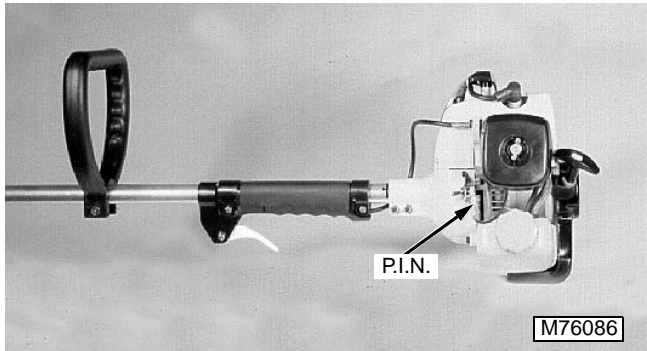

**HEDGECLIPPER—21HC**

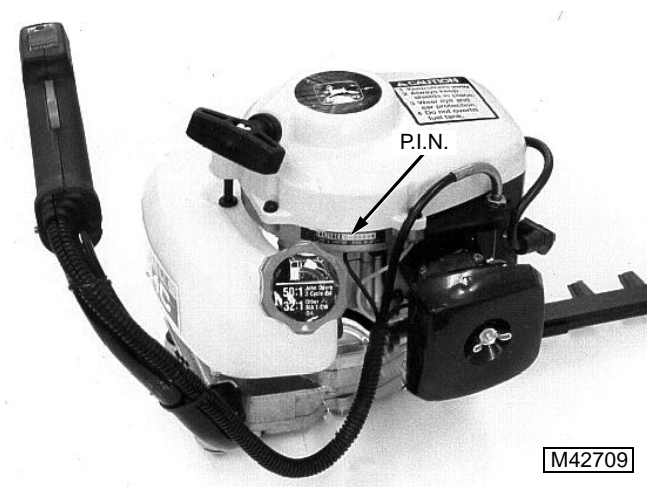

**BLOWER—45BP**

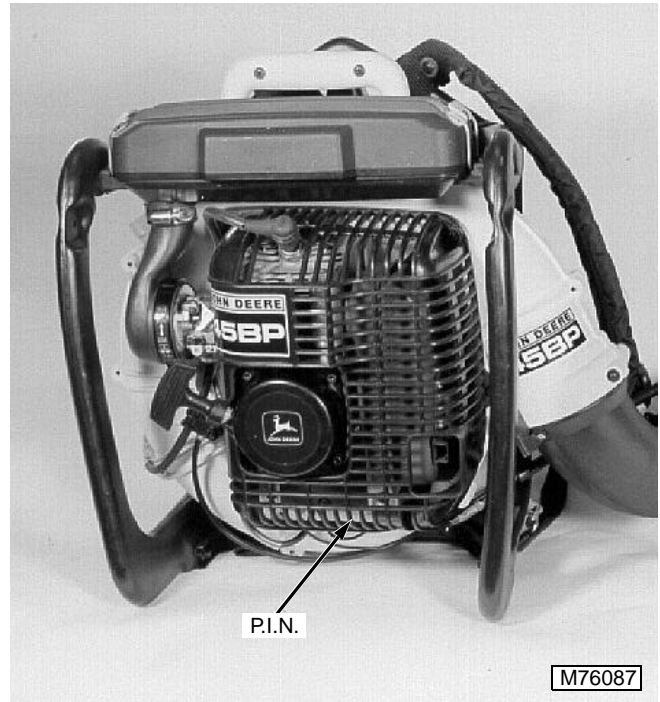

**BUY NOW**

**Then Instant Download  
the Complete Manual  
Thank you very much!**