

SECTION 1 GENERAL

Group 1 Safety hints	1-1
Group 2 Specifications	1-5
Group 3 Periodic replacement	1-13

SECTION 2 REMOVAL AND INSTALLATION OF UNIT

Group 1 Structure	2-1
Group 2 Removal and installation of unit	2-2

SECTION 3 POWER TRAIN SYSTEM

Group 1 Structure and operation	3-1
Group 2 Inspection and troubleshooting	3-13
Group 3 Disassembly and assembly	3-19

SECTION 4 BRAKE SYSTEM

Group 1 Structure and function	4-1
Group 2 Operational checks and troubleshooting	4-8
Group 3 Tests and adjustments	4-10

SECTION 5 STEERING SYSTEM

Group 1 Structure and function	5-1
Group 2 Operational checks and troubleshooting	5-10
Group 3 Disassembly and assembly	5-12

SECTION 6 HYDRAULIC SYSTEM

Group 1 Structure and function	6-1
Group 2 Operational checks and troubleshooting	6-15
Group 3 Disassembly and assembly	6-20

SECTION 7 ELECTRICAL SYSTEM

Group 1 Component location	7-1
Group 2 Electrical circuit	7-2
Group 3 Component specification	7-12
Group 4 Connector destination	7-13
Group 5 Troubleshooting	7-15

SECTION 8 MAST

Group 1 Structure	8-1
Group 2 Operational checks and troubleshooting	8-5
Group 3 Adjustment	8-8
Group 4 Removal and installation	8-11

GROUP 1 SAFETY HINTS

Careless performing of the easy work may cause injuries.

Take care to always perform work safely, at least observing the following.

- Oil is a dangerous substance. Never handle oil, grease or oily clothes in places where there is any fire or flame.

As preparation in case of fire, always know the location and directions for use of fire extinguishers and other fire fighting equipment.

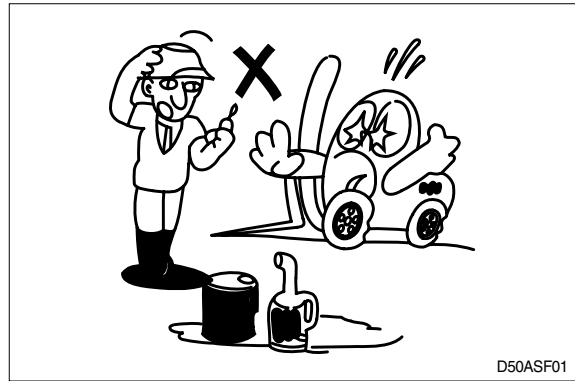

- Wear well-fitting helmet, safety shoes and working clothes. When drilling, grinding or hammering, always wear protective goggles. Always do up safety clothes properly so that they do not catch on protruding parts of machines. Do not wear oily clothes. When checking, always release battery plug.

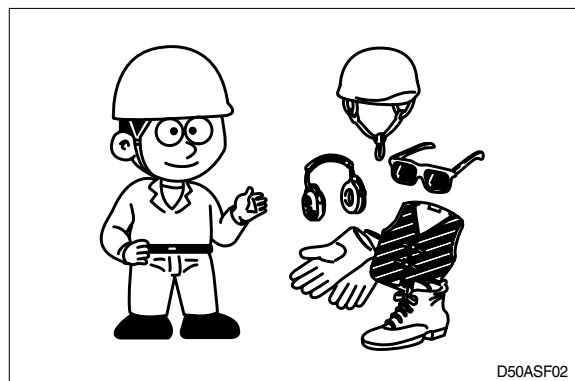

- Flames should never be used instead of lamps. Never use a naked flame to check leaks or the level of oil or electrolyte.

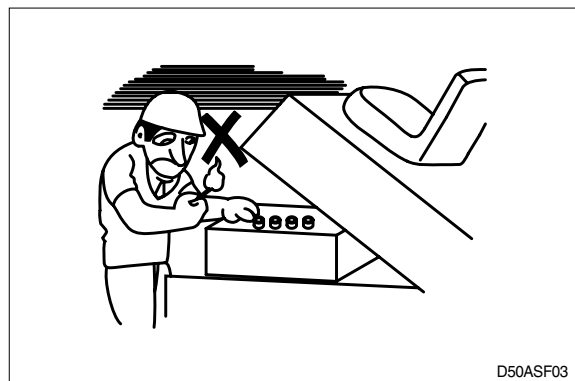

- Exhaust gas is dangerous. Provide adequate ventilation when working a closed space.

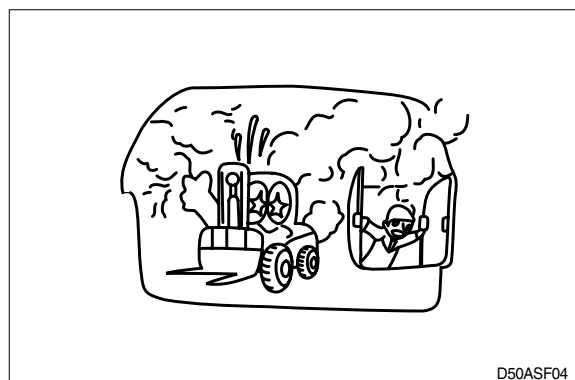

⚠ Be particularly careful when removing the radiator cap and the hydraulic oil tank filler cap, if this is done immediately after using the machine, there is a danger that boiled oil may spurt out.

- The procedure for releasing the hydraulic pressure is as follows : lower the fork to the ground, and stop the engine(Motor), move the control levers to each position two or three times.

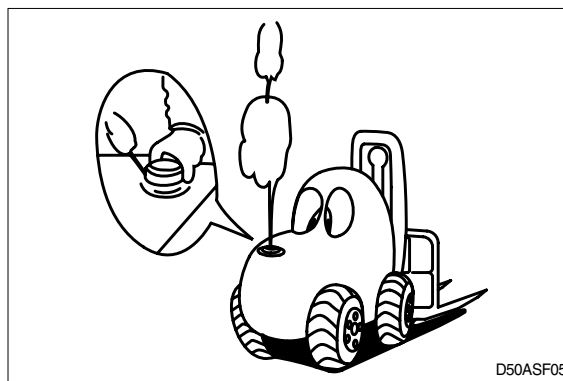

- When working on top of the machine, be careful not to lose your balance and fall.



- Hand a caution sign in the operator's compartment (For example **Do not start** or **Maintenance in progress**).

This will prevent anyone from starting or moving the machine by mistake.

⚠ It is extremely dangerous to try to check the fan belt tension while the engine is running.

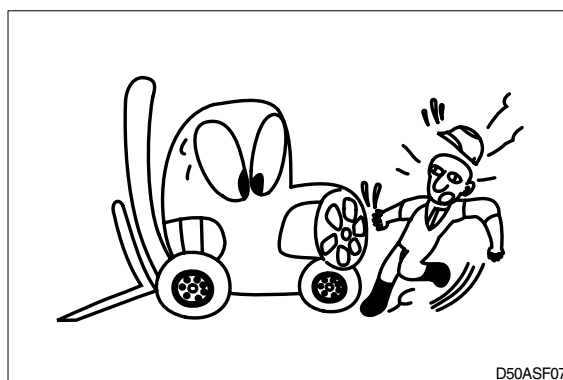

When inspecting the engine is running parts, or near such parts, always stop the engine first.

Before checking or servicing accumulator or piping, depress brake pedal repeatedly to release pressure.

- Park the machine on firm, flat ground.
Lower the fork to the ground and stop the engine.
Return each lever to **NEUTRAL** and apply the brake lock.

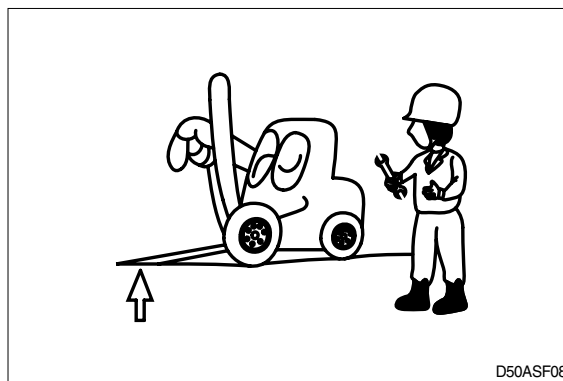

- Immediately remove any oil or grease on the floor of the operator's compartment, or on the handrail. It is very dangerous if someone slips while on the machine.

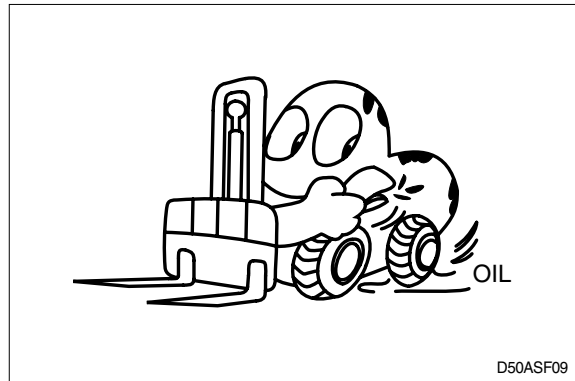

- When working with others, choose a group leader and work according to his instructions. Do not perform any maintenance beyond the agreed work.

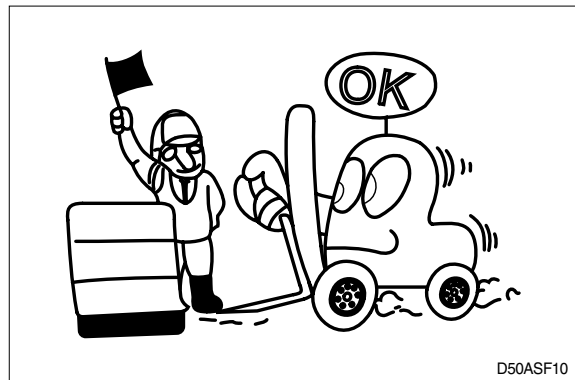

- Always remember that the hydraulic oil circuit is under pressure. When feeding or draining the oil or carrying out inspection and maintenance, release the pressure first.

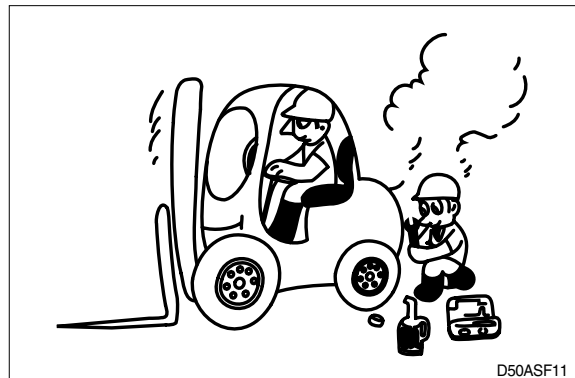

- Unless you have special instructions to the contrary, maintenance should always be carried out with the engine stopped. If maintenance is carried out with the engine running, there must be two men present : one sitting in the operator's seat and the other one performing the maintenance. In such a case, never touch any moving part.

- Thoroughly clean the machine. In particular, be careful to clean the filler caps, grease fittings and the area around the dipsticks. Be careful not to let any dirt or dust into the system.
- Always use HYUNDAI Forklift genuine parts for replacement.
- Always use the grades of grease and oil recommended by HYUNDAI Forklift. Choose the viscosity specified for the ambient temperature.
- Always use pure oil or grease, and be sure to use clean containers.
- When checking or changing the oil, do it in a place free of dust, and prevent any dirt from getting into the oil.
- Before draining the oil, warm it up to a temperature of 30 to 40°C.
- After replacing oil, filter element or strainer, bleed the air from circuit.
- When the strainer is located in the oil filler, the strainer must not be removed while adding oil.
- When changing the oil filter, check the drained oil and filter for any signs of excessive metal particles or other foreign materials.
- When removing parts containing O-ring, gaskets or seals, clean the mounting surface and replace with new sealing parts.
- After injecting grease, always wipe off the oil grease that was forced out.
- Do not handle electrical equipment while wearing wet places, as this can cause electric shock.
- During maintenance do not allow any unauthorized person to stand near the machine.
- Be sure you fully understand the contents of the operation. It is important to prepare necessary tools and parts and to keep the operating area clean.
- When checking an open gear case there is a risk of dropping things in. Before removing the covers to inspect such cases, empty everything from your pockets. Be particularly careful to remove wrenches and nuts.
- Way to use dipstick
Push the dipstick fully into the guide, and then pull out.

Carrying out other difficult maintenance work carelessly can cause unexpected accidents. If you consider the maintenance is too difficult, always request the HYUNDAI Forklift distributor to carry out it.

GROUP 2 SPECIFICATIONS

1. MAJOR COMPONENTS

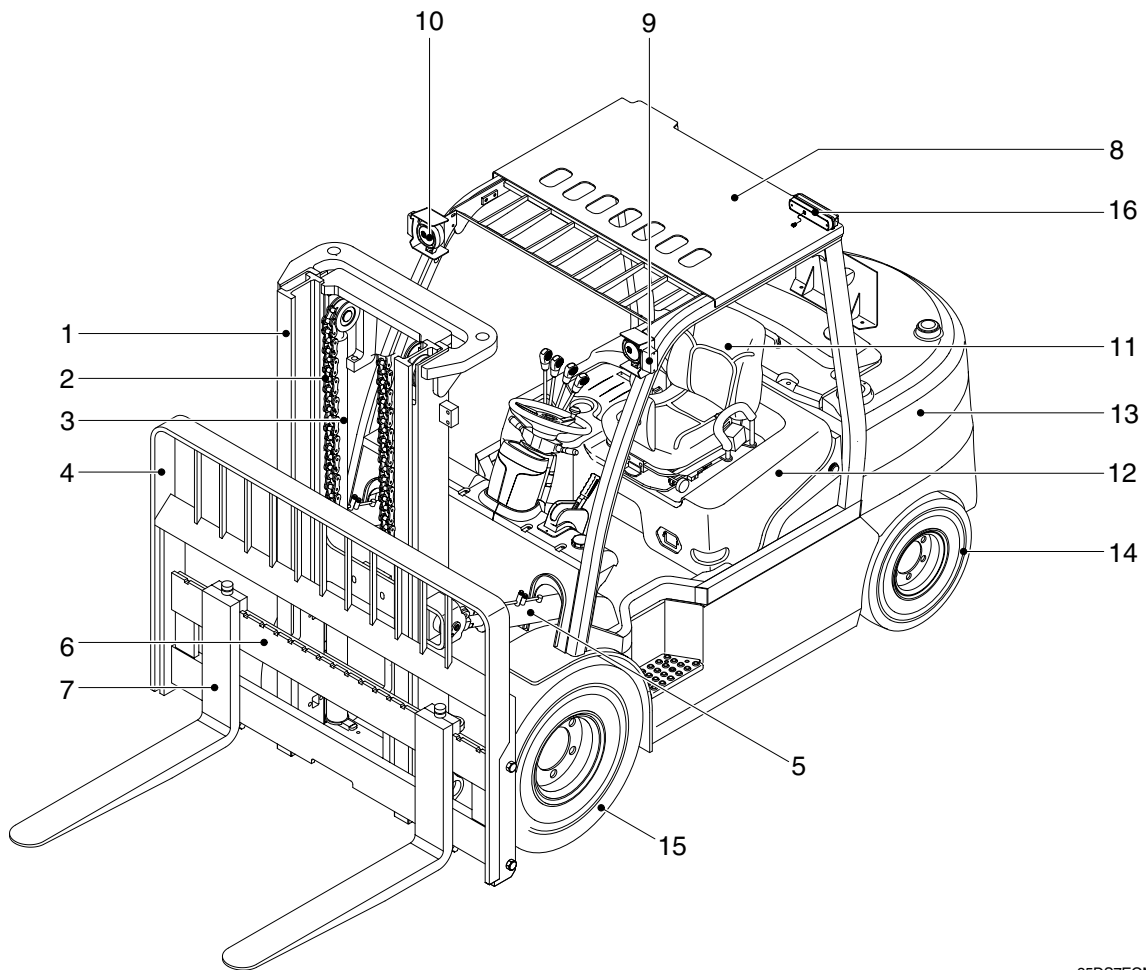

35DS7EOM54

- | | | |
|-----------------|--------------------|--------------------------|
| 1 Mast | 7 Forks | 13 Counterweight |
| 2 Lift chain | 8 Overhead guard | 14 Rear wheel |
| 3 Lift cylinder | 9 Turn signal lamp | 15 Front wheel |
| 4 Backrest | 10 Head lamp | 16 Rear combination lamp |
| 5 Tilt cylinder | 11 Operator's seat | |
| 6 Carriage | 12 Bonnet | |

2. SPECIFICATIONS

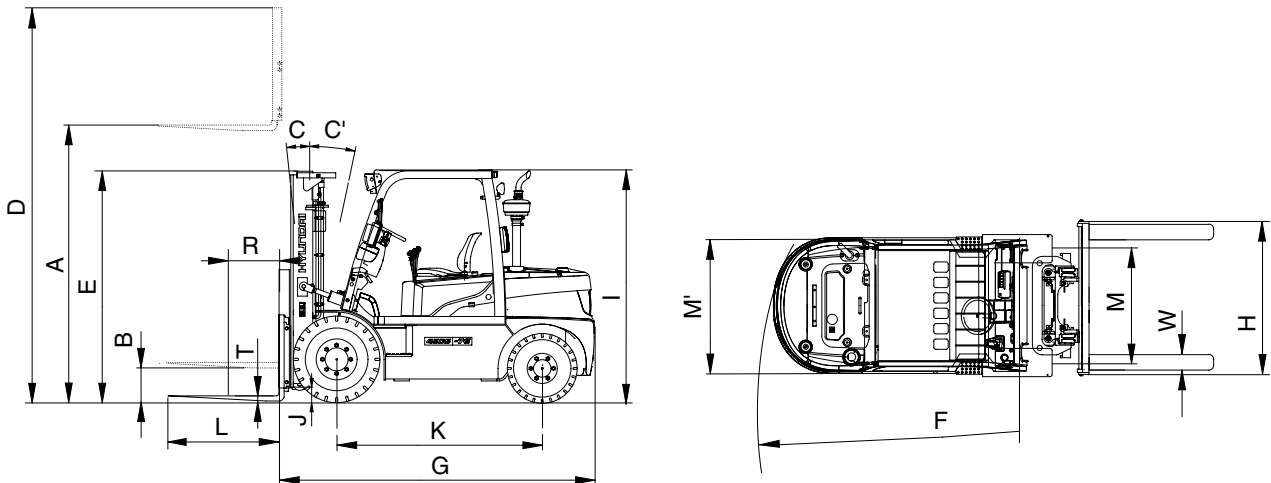

35DS7ESP01

Model		Unit	35D-7E	40D-7E	45D-7E	50D-7AE	
Capacity		kg	3500	4000	4500	5000	
Load center	R	mm	600	←	←	←	
Weight(Unloaded)		kg	5832	6392	6807	7302	
Fork	Lifting height	A	mm	←	←	2930	
	Free lift	B	mm	←	←	←	
	Lifting speed(Unload/Load)		mm/sec	570/550	570/540	570/530	490/460
	Lowering speed(Unload/Load)		mm/sec	500/500	←	←	←
	L × W × T	L,W,T	mm	1070 × 122 × 50	1070 × 150 × 50	1220 × 150 × 50	1200 × 150 × 60
Mast	Tilt angle (forward/backward)	C/C'	degree	8/10	←	←	
	Max height	D	mm	4224	←	4235	
	Min height	E	mm	2235	2220	2220	
Body	Travel speed		km/h	27.7	26.7	26.7	
	Gradeability		degree	22.8	22.4	18.7	
	Min turning radius(Outside)	F	mm	2840	2900	2950	
ETC	Max hydraulic pressure		kgf/cm ²	210	←	←	
	Hydraulic oil tank		l	66	←	←	
	Fuel tank		l	100	←	←	
Overall length	G	mm	3140	3195	3245	3315	
Overall width	H	mm	1400	1740	←	←	
Overhead guard height	I	mm	2240	←	←	←	
Ground clearance	J	mm	170	155	←	←	
Wheel base	K	mm	2000	←	←	←	
Wheel tread front/rear	M, M'	mm	1162/1140	1312/1140	←	←	

3. SPECIFICATION FOR MAJOR COMPONENTS

1) ENGINE

Item	Unit	Specification
Model	-	HYUNDAI D4DD
Type	-	4 cycle turbocharged diesel type
Cooling Method	-	Water cooling
Number of cylinders and arrangement	-	4 cylinders, In-line
Firing order	-	1-3-4-2
Combustion chamber type	-	Direct injection
Cylinder bore X stroke	mm(in)	104 × 115(4.1 × 4.5)
Piston displacement	cc(cu in)	3907(238)
Compression ratio	-	17.5 : 1
Rated gross horse power	hp/rpm	95/2300
Maximum torque at rpm	kgf · m/rpm	35/1600
Engine oil quantity	l (U.S.gal)	8.5(2.2)
Dry weight	kg(lb)	353(778)
High idling speed	rpm	2500 ± 50
Low idling speed	rpm	800 ± 50
Rated fuel consumption	g/ps.hr	140.2(at 1700rpm)
Starting motor	V-kW	24-5
Alternator	V-A	24-50
Battery	V-AH	24-75
Fan belt deflection	mm(in)	10~15(0.39~0.59)

(2) MAIN PUMP

Item	Unit	Specification
Type	-	Fixed displacement gear pump
Capacity	cc/rev	50
Maximum operating pressure	bar	250
Rated speed (Max/Min)	rpm	3000/600

(3) MAIN CONTROL VALVE

Item	Unit	Specification
Type	-	Sectional
Operating method	-	Mechanical
Main relief valve pressure	bar	210/150
Flow capacity	lpm	125

(4) POWER TRAIN DEVICES

Item		Specification		
Torque converter	Model	DE 280 (KAPEC)		
	Type	3 Element, 1 stage, 2 phase		
	Stall ratio	2.25 : 1		
Transmission	Type	Power shift		
	Gear shift(FWD/REV)	2/2		
	Control	Electrical single lever type		
	Overhaul ratio	FWD	1st : 2.550	2nd : 1.218
REV		1st : 2.550	2nd : 1.218	
Axle	Type	Front-wheel drive type, fixed location		
	Gear ratio	11.692		
Wheels	Q'ty(FR/RR)	Single : 2/2	Double : 4/2	
	Front(drive)	Single	3.5 ton : 8.25-15-14 PR	4.0~5.0 ton : 300-15-18 PR
		Double	7.5-16-12 PR	
Rear(steer)	3.5~4.5 ton : 7.0-12-12 PR	5 ton : 7.0-12-14 PR		
Brakes	Travel	Front wheel, wet disc brake		
	Parking	Ratchet, drum brake		
Steering	Type	Full hydraulic, power steering		
	Steering angle	74.8° to both right and left angle, respectively		

4. TIGHTENING TORQUE FOR MAJOR COMPONENTS

NO	ITEMS		SIZE	kgf · m	lbf · ft
1	Engine	Engine mounting bolt, nut	M16 × 2.0	7.5	54
2		Radiator mounting bolt, nut	M10 × 1.5	6.9 ± 1.4	50 ± 10
3	Hydraulic system	MCV mounting bolt, nut	M12 × 1.75	2.5	18
4		Steering unit mounting bolt	M10 × 1.5	4 ± 0.5	29 ± 3.6
5		Hydraulic pump mounting bolt	M14 × 1.5	21 ± 3.1	152 ± 22
6	Power train system	Transmission mounting bolt, nut	M16 × 1.5	31.3 ± 4.7	227 ± 34
7		Torque converter mounting bolt	M10 × 1.5	6.9 ± 1.4	50 ± 10
8		Drive axle mounting bolt, nut	M24 × 2.0	62.5 ± 9.5	452 ± 69
9		Steering axle mounting bolt, nut	M14 × 2.0	19.6 ± 2.9	142 ± 21
10		Front wheel mounting nut	M22 × 1.5	62 ± 9.3	448 ± 67
11		Rear wheel mounting nut	M20 × 1.5	60.0 ± 5.0	434 ± 36
12	Others	Counterweight mounting bolt	M30 × 3.5	199 ± 29.9	1440 ± 216
13		Operator's seat mounting nut	M 8 × 1.25	2.5 ± 0.5	18.1 ± 3.6
14		Head guard mounting bolt	M12 × 1.75	6.2	45

5. TORQUE CHART

Use following table for unspecified torque.

1) BOLT AND NUT

(1) Coarse thread

Bolt size	8T		10T	
	kgf · m	lbf · ft	kgf · m	lbf · ft
M 6 × 1.0	0.85 ~ 1.25	6.15 ~ 9.04	1.14 ~ 1.74	8.2 ~ 12.6
M 8 × 1.25	2.0 ~ 3.0	14.5 ~ 21.7	2.73 ~ 4.12	19.7 ~ 29.8
M10 × 1.5	4.0 ~ 6.0	28.9 ~ 43.4	5.5 ~ 8.3	39.8 ~ 60
M12 × 1.75	7.4 ~ 11.2	53.5 ~ 79.5	9.8 ~ 15.8	71 ~ 114
M14 × 2.0	12.2 ~ 16.6	88.2 ~ 120	16.7 ~ 22.5	121 ~ 167
M16 × 2.0	18.6 ~ 25.2	135 ~ 182	25.2 ~ 34.2	182 ~ 247
M18 × 2.5	25.8 ~ 35.0	187 ~ 253	35.1 ~ 47.5	254 ~ 343
M20 × 2.5	36.2 ~ 49.0	262 ~ 354	49.2 ~ 66.6	356 ~ 482
M22 × 2.5	48.3 ~ 63.3	350 ~ 457	65.8 ~ 98.0	476 ~ 709
M24 × 3.0	62.5 ~ 84.5	452 ~ 611	85.0 ~ 115	615 ~ 832
M30 × 3.5	124 ~ 168	898 ~ 1214	169 ~ 229	1223 ~ 1655
M36 × 4.0	174 ~ 236	1261 ~ 1703	250 ~ 310	1808 ~ 2242

(2) Fine thread

Bolt size	8T		10T	
	kgf · m	lbf · ft	kgf · m	lbf · ft
M 8 × 1.0	2.17 ~ 3.37	15.7 ~ 24.3	3.04 ~ 4.44	22.0 ~ 32.0
M10 × 1.25	4.46 ~ 6.66	32.3 ~ 48.2	5.93 ~ 8.93	42.9 ~ 64.6
M12 × 1.25	7.78 ~ 11.58	76.3 ~ 83.7	10.6 ~ 16.0	76.6 ~ 115
M14 × 1.5	13.3 ~ 18.1	96.2 ~ 130	17.9 ~ 24.1	130 ~ 174
M16 × 1.5	19.9 ~ 26.9	144 ~ 194	26.6 ~ 36.0	193 ~ 260
M18 × 1.5	28.6 ~ 43.6	207 ~ 315	38.4 ~ 52.0	278 ~ 376
M20 × 1.5	40.0 ~ 54.0	289 ~ 390	53.4 ~ 72.2	386 ~ 522
M22 × 1.5	52.7 ~ 71.3	381 ~ 515	70.7 ~ 95.7	512 ~ 692
M24 × 2.0	67.9 ~ 91.9	491 ~ 664	90.9 ~ 123	658 ~ 890
M30 × 2.0	137 ~ 185	990 ~ 1338	182 ~ 248	1314 ~ 1795
M36 × 3.0	192 ~ 260	1389 ~ 1879	262 ~ 354	1893 ~ 2561

2) PIPE AND HOSE(FLARE TYPE)

Thread size	Width across flat(mm)	kgf · m	lbf · ft
1/4"	19	4	28.9
3/8"	22	5	36.2
1/2"	27	9.5	68.7
3/4"	36	18	130
1"	41	21	152
1-1/4"	50	35	253

3) PIPE AND HOSE(ORFS TYPE)

Thread size	Width across flat(mm)	kgf · m	lbf · ft
9/16-18	19	4	28.9
11/16-16	22	5	36.2
13/16-16	27	9.5	68.7
1-3/16-12	36	18	130
1-7/16-12	41	21	152
1-11/16-12	50	35	253

4) FITTING

Thread size	Width across flat(mm)	kgf · m	lbf · ft
1/4"	19	4	28.9
3/8"	22	5	36.2
1/2"	27	9.5	68.7
3/4"	36	18	130
1"	41	21	152
1-1/4"	50	35	253

6. RECOMMENDED LUBRICANTS

Use only oils listed below or equivalent.

Do not mix different brand oil.

Service point	Kind of fluid	Capacity l (U.S.gal)	Ambient temperature °C (°F)						
			-20 (-4)	-10 (14)	0 (32)	10 (50)	20 (68)	30 (86)	40 (104)
Engine oil pan	Engine oil	8.5(2.2)	SAE 30						
			SAE 10W						
			SAE 10W-30						
			SAE 15W-40						
Torque converter transmission	T/M oil	12 (3.2)	AFT DEXRON III						
Axle	Gear oil	10.5 (2.8)	Mobilfluid 424						
Hydraulic tank	Hydraulic oil	66 (17.4)	ISO VG32						
			ISO VG46						
			ISO VG68						
Fuel tank	Diesel fuel	100 (26.4)	ASTM D975 No.1						
			ASTM D975 No.2						
Fitting (Grease nipple)	Grease	-	NLGI No.1						
			NLGI No.2						
Brake reservoir tank	Hyd oil	-	Azola ZS10 (Hydraulic oil SAE 10W)						
Radiator	Antifreeze:Water 50:50	21.5 (5.7)	Ethylene glycol base permanent type						

NOTES :

- ① SAE numbers given to engine oil should be selected according to ambient temperature.
- ② For engine oil used in engine oil pan, use SAE 10W oil when the temperature at the time of engine start up is below 0°C, even if the ambient temperature in daytime is expected to rise to 10°C or more.
- ③ If any engine oil of API service class CF is used instead of class CH4 engine oil, the frequency of oil change must be doubled.

BUY NOW

**Then Instant Download
the Complete Manual
Thank you very much!**