

INTRODUCTION

DESCRIPTION

Gear pumps have several sections and are made with a single set (single stage) of gears or with multiple sets (tandem) of gears. A single stage pump has two covers and the gear housing with the gears. Seals are used to prevent leaks between the sections. Tandem pumps have a gear housing for each set of gears. Most tandem pumps also have a center section for the bearings. The inlet and outlet ports are normally on the gear housing or rear cover. The front cover has the seal for the input shaft. The input shaft is connected to a driven sprocket, coupling, or gear by splines or a key.

All the gear pumps have devices that keep the thrust clearance at a minimum when the pressure increases. When the pressure is low, the clearance increases to pre-

vent wear. To prevent leakage when the pressure is high, the oil from the outlet side of the pump is transferred to a wear plate. The oil pushes the wear plate against the gears. Some pumps have bearing blocks that move closer to the gears when the pressure increases.

OPERATION

Gear pumps have the teeth of the gears engaged in the center of the pump. When the input shaft is turned, the drive gear turns the driven gear. The oil in the inlet chamber is moved out from the center by the teeth of rotating gears. The oil between the teeth is moved around the pumping chamber to the outlet chamber. The oil is pushed from the outlet chamber by the gear teeth that are beginning to engage.

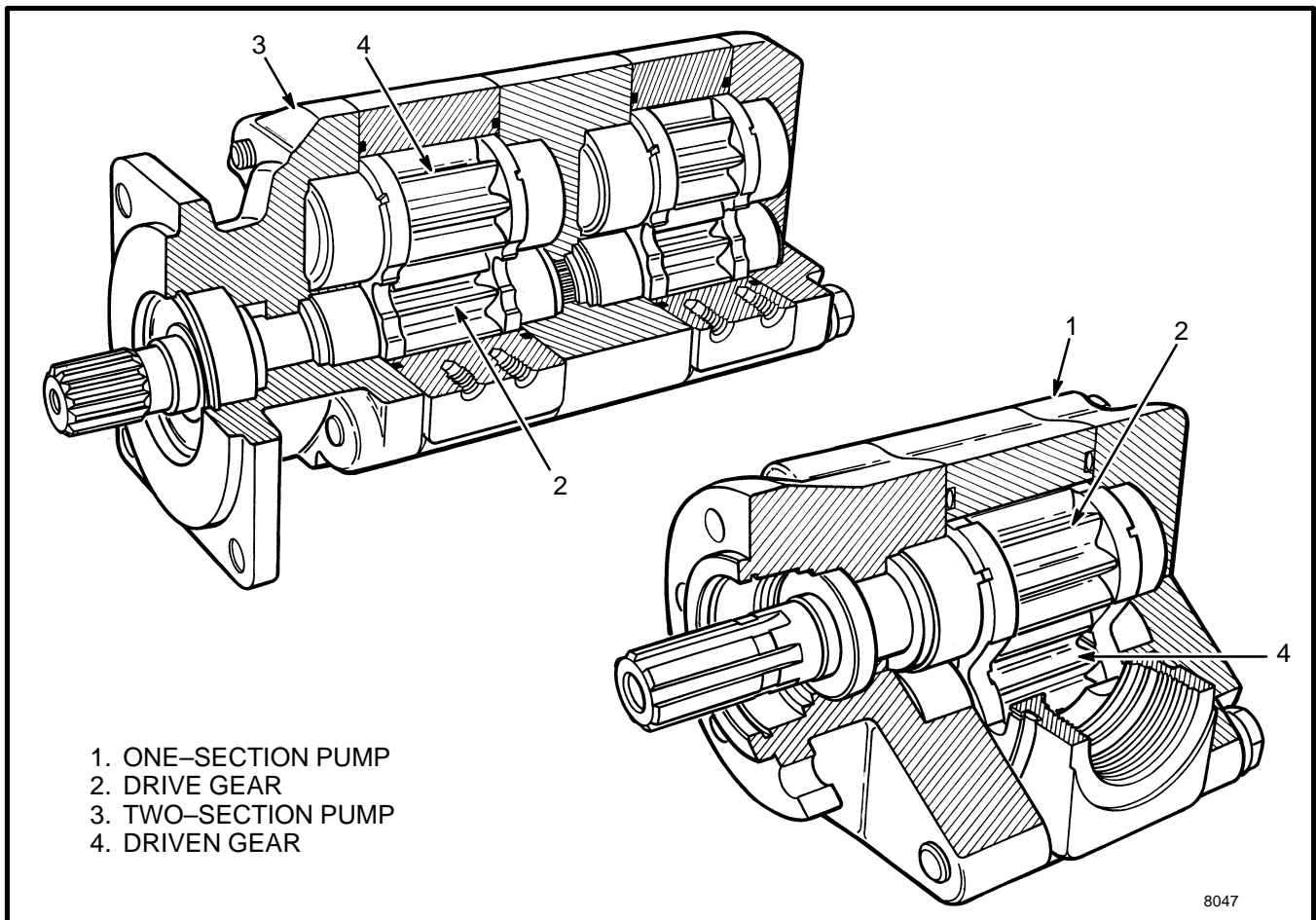

FIGURE 1. TYPES OF GEAR PUMPS

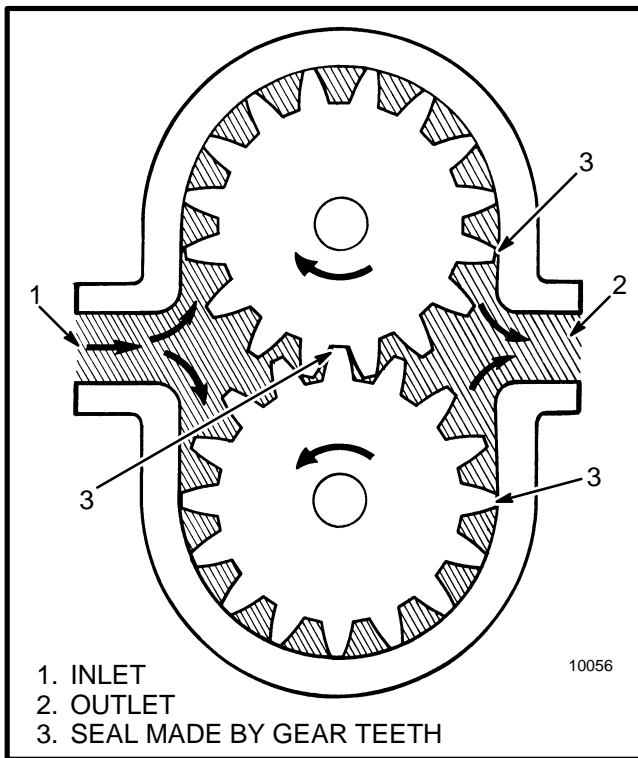

FIGURE 2. OPERATION OF GEAR PUMP

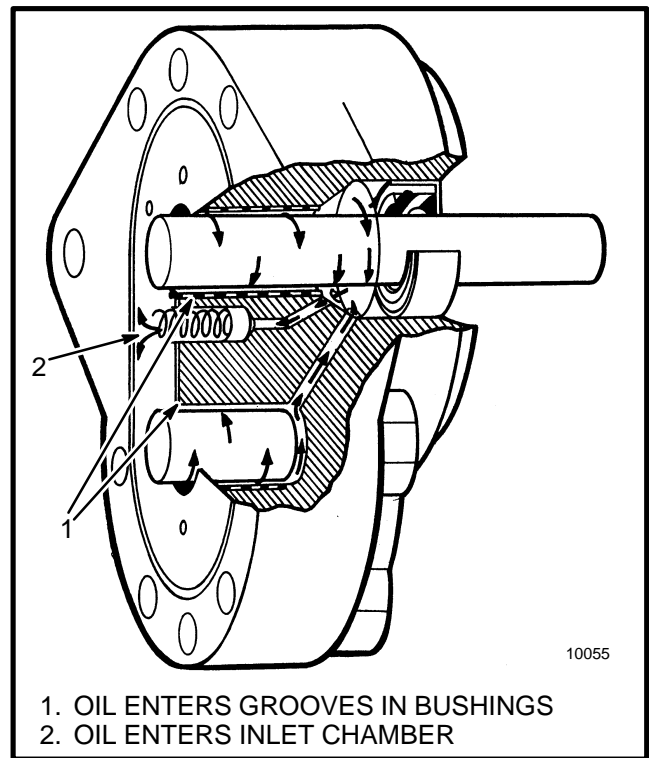

FIGURE 3. CHECK VALVE

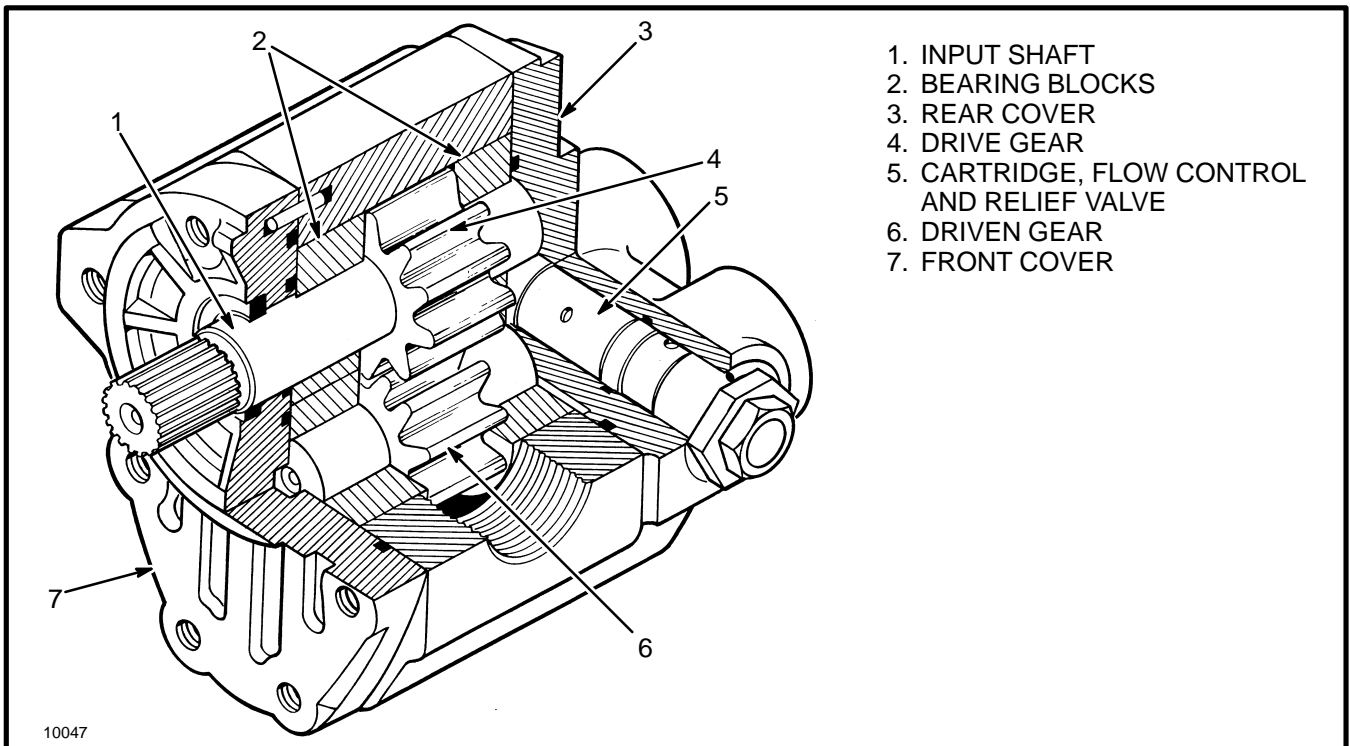

FIGURE 4. BASIC PARTS OF A GEAR PUMP

The gears and bearings are lubricated by oil from the outlet side of the pump. A small amount of oil flows past the gears and into the bearings and to the front seal cavity. A check ball and spring are installed in some pumps to keep pressure on the oil in this passage. The oil pres-

sure prevents air leaks through the front seal and makes sure there is oil to the bearings. When the pressure increases to the spring setting, the ball moves from its seat and oil flows to the inlet chamber.

Flow Control Valve

Some of the pumps have a flow control valve in the rear cover. The flow control valve has either a piston and spring, or a cartridge with a piston and spring. The piston has an orifice that permits a constant volume of oil to flow to the controlled flow port. When the pump speed increases, the piston moves to partly open the passage to the main control valve. This action keeps constant the pressure difference across the orifice. A constant pressure difference between both sides of an orifice causes a constant flow through the orifice.

Relief Valve

Some pumps have a relief valve installed in a cartridge or in a bore in the rear cover. Relief valves in the pump prevent the pressure in the controlled flow system from increasing beyond the specifications. The relief valve in the cartridge has a poppet and spring, with the seat for the poppet in the cartridge. The relief valve and flow control valve on some pumps are installed in the same cartridge. Some of the relief valves that are installed in the pumps are adjustable only with shims. Replace the cartridge if the relief valve has a problem.

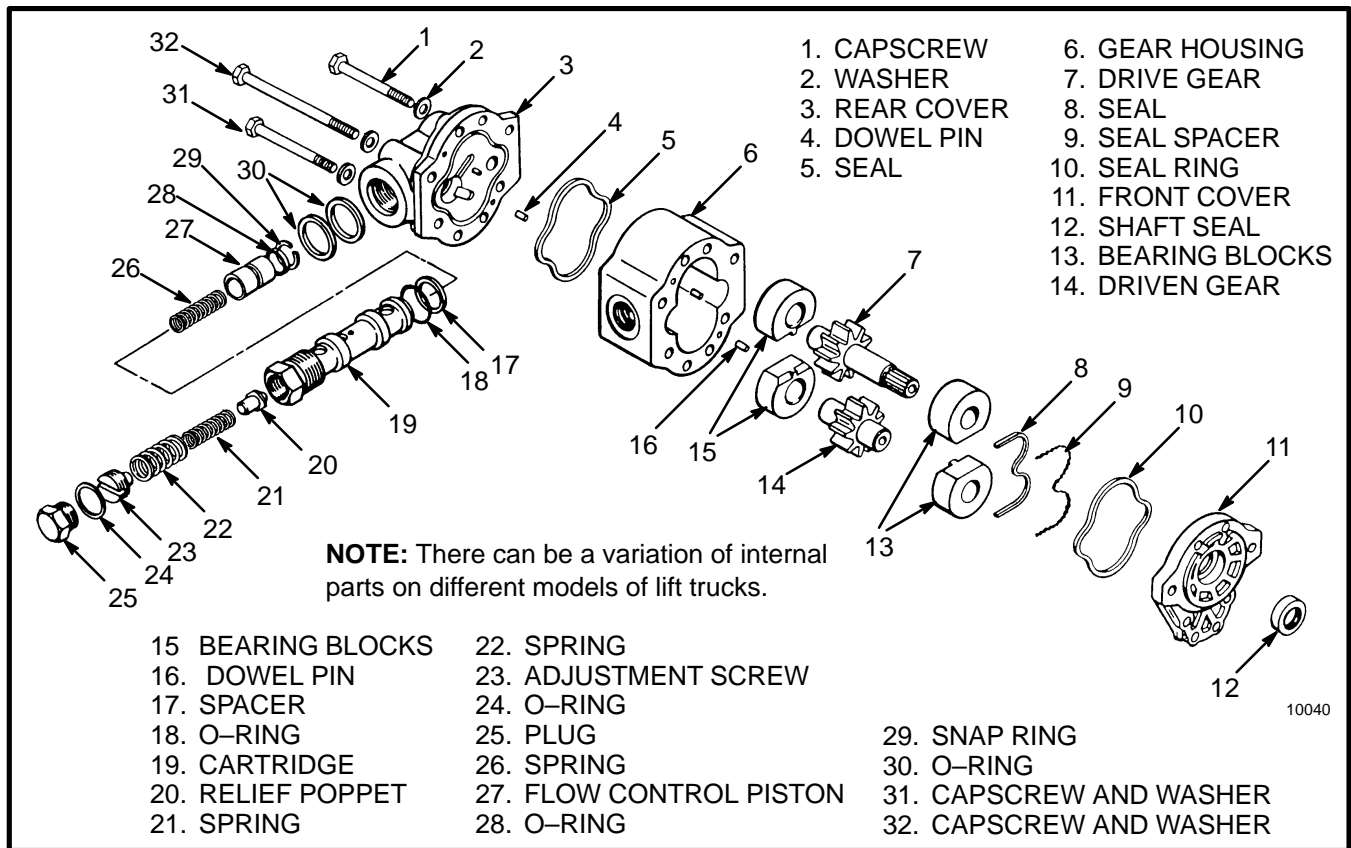

FIGURE 5. HYDRAULIC GEAR PUMP, SINGLE-STAGE

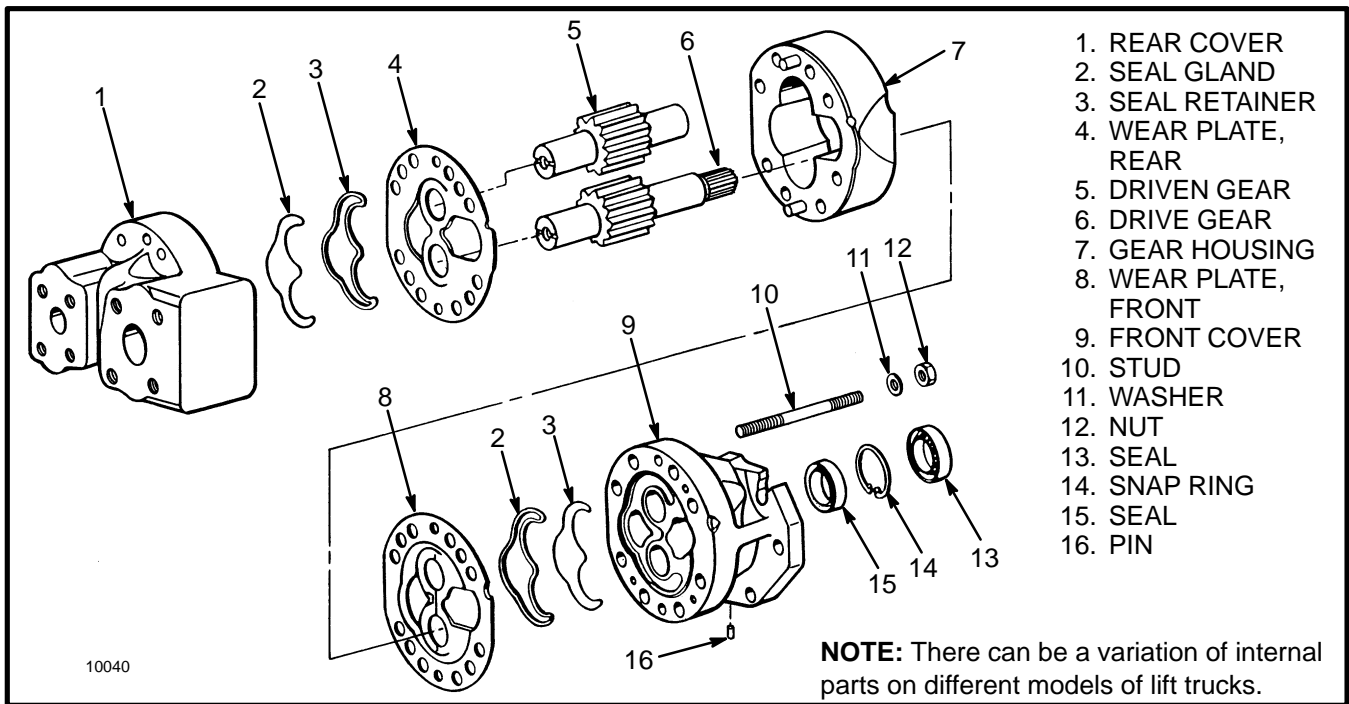

FIGURE 6. HYDRAULIC GEAR PUMP, SINGLE-STAGE

REPAIRS

NOTE: Worn or damaged seals are the most common cause of pump repair. The pump bearings, gears and shafts also wear. Many service persons do not repair a worn pump because the cost of repairs can be greater than the cost of a new pump. The seals can be replaced in the hydraulic pump. If the pump will be rebuilt, the following general procedures are for repairing gear pumps.

REMOVAL

WARNING

Make sure the carriage is lowered before disconnecting any parts of the hydraulic system.

1. If the lift truck is equipped with a valve on the tank, the valve must be closed before removing the pump. If there is no valve on the tank, remove the breather and install a plug. This action prevents the tank from draining too fast when the inlet line is disconnected.

2. On some electric lift trucks, the pump is installed inside of the hydraulic tank. Drain the tank and remove the cover on the side of the tank. See THE HYDRAULIC SYSTEM, E20-120B, 1900 SRM 161.

3. Disconnect the hoses from the pump. Put caps on all the fittings. Be careful so that the inlet hose is not damaged during removal.

4. If the pump is driven by a drive shaft, disconnect the drive shaft at the pump.

WARNING

Some of the hydraulic pumps are very heavy. Use a lifting device when removing or installing the pump.

5. Remove the capscrews holding the pump housing to the mount.

6. Remove the pump from the lift truck.

DISASSEMBLY

NOTE: See the illustration in the Figure that is similar the pump being repaired. The illustration can have parts that are different than those in the actual pump that is being repaired.

1. Remove the gear or sprocket from the input shaft.

2. Before disassembling the pump, make alignment marks on all the housings. Some of the housings can be assembled in the wrong positions, which will cause fail-

ure or increased wear. Carefully clean the outside of the pump.

NOTE: The inlet ports in most gear pumps are larger than the outlet ports.

NOTE: If the pump is held in a vise for disassembly, make sure the vise does not hold the pump too tightly and cause distortion of the pump body.

NOTE: The position of the seals is important. In some pumps the direction of pump rotation is changed by changing the position of the seals and housings. The holes in the seals must be aligned with the oil passages in the housing sections. The oil passage for the thrust plates is in the outlet chamber.

Make sure that you make careful notes of the location and orientation of the parts and seals during disassem-

bly. Some of the parts are similar, but not exactly the same and it can be difficult to make an identification if they are mixed.

3. Remove the capscrews or nuts that hold the housings together. Use a plastic hammer to separate the housings. Do not damage the machined surfaces.

4. Remove the gears and thrust plates (if used). Make a note of the positions of the thrust plates, seals and gaskets. Do not use a punch to mark the parts. Remove any springs and check valves.

5. Remove the bearings with a puller. In some pumps the bearing blocks or plates must be replaced with the bearings.

6. Remove the front seal.

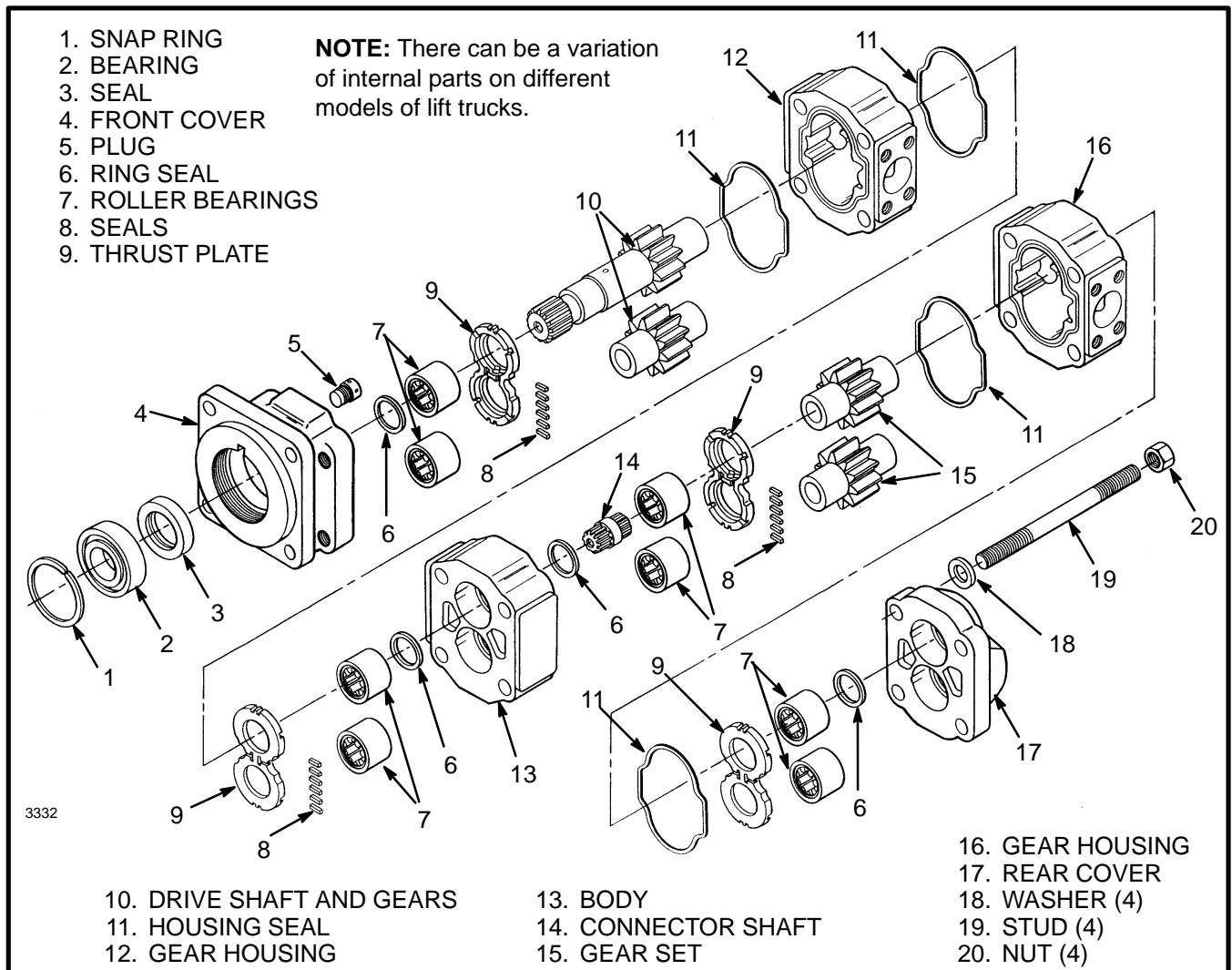

FIGURE 7. HYDRAULIC GEAR PUMP, TANDEM

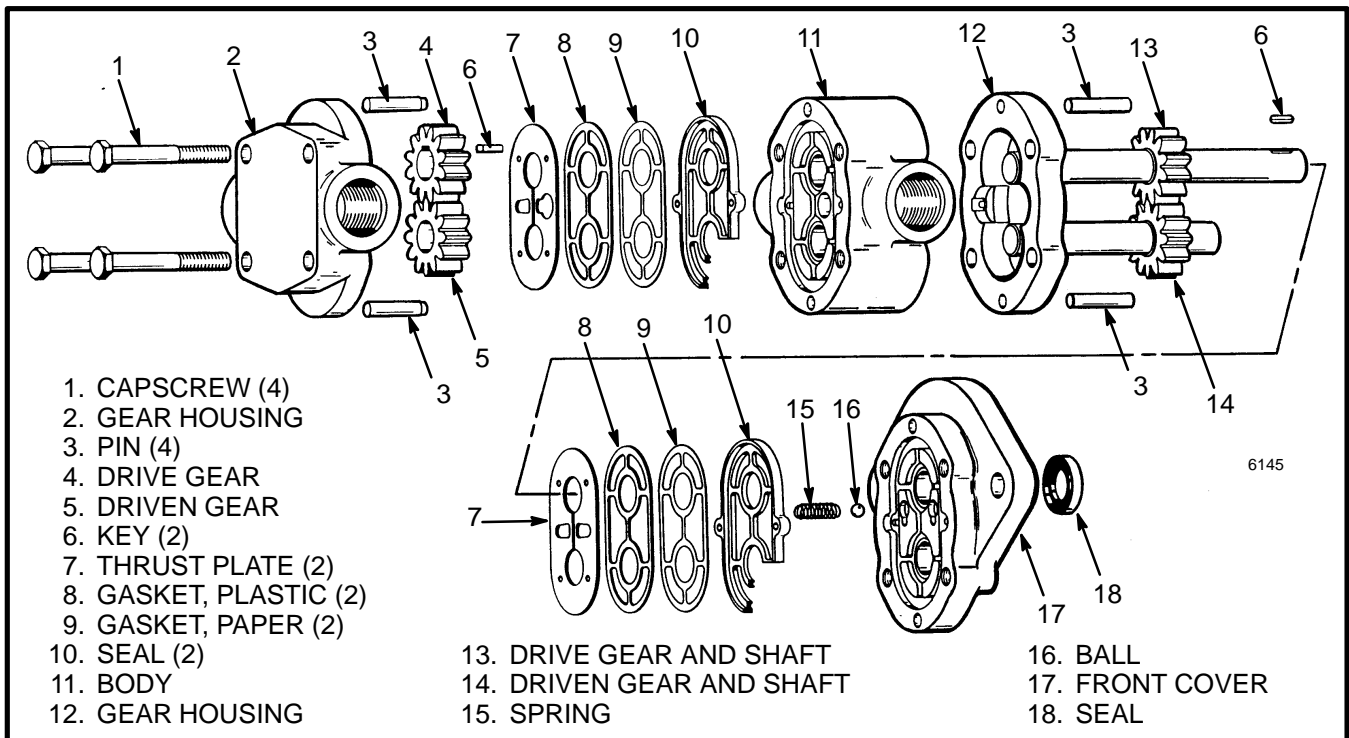

FIGURE 8. HYDRAULIC GEAR PUMP, TANDEM

CLEANING

Clean all parts of the pump with solvent. Use compressed air to dry the parts. Do not use a cloth to dry the parts. Pieces of the cloth can cause restrictions in the hydraulic system. Make sure the work area and tools are very clean.

CAUTION

Any dirt that enters the hydraulic system can cause damage to the parts.

INSPECTION

1. Inspect the outside edges of the gear teeth for grooves or scratches. If the edges of the gear teeth are sharp, use emery cloth to break the edges. Replace the gears if there are deep grooves on the gears.

2. If the gear shafts have grooves or are worn more than 0.05 mm (0.002 in), they must be replaced. Wear on the seal area of the shaft indicates that there is dirt in the oil or a hard seal. Inspect the seal to see if it has been too hot. Look for small cracks in the seal surfaces. If the seal was too hot or the wrong oil was used, the seal will be too hard or too soft. Inspect the splines or key groove for damage.

NOTE: Some pump bodies will show gear marks where the gears rotate because of the small clearances between the parts. These gear marks do not indicate a worn or damaged pump unless the pump will not supply the volume and pressure shown in the specifications.

3. Inspect the gear housing for wear or grooves. Most wear occurs on the inlet side of the gear chamber. Put a straight edge across the inlet side of the gear chamber. If a 0.13 mm (0.005 in) thickness gauge fits between the straight edge and the housing, the gear housing must be replaced. If the gear housing is worn, inspect the bearings for wear. If the system pressure is too high, the gear housings will wear quickly. Grooves in the gear chamber indicate dirt is in the oil. Small holes in the outlet side of the gear chamber indicate that cavitation has occurred. Make sure the inlet hose, fittings and tank have no restrictions. Cavitation can also occur when the engine speed is too high.

If the surfaces of the gear chamber or gear teeth have blue marks, the pump was too hot. Heat damage in the pump can be caused by hot oil or lack of oil. Check the front seal surface to see if air was entering the pump through the front seal. Make sure the oil is the correct viscosity. The wrong viscosity oil can increase leakage within the pump. Leakage inside the pump increases the oil temperature.

(More Content includes: Brake system, Capacities, and specifications, Frame, Hydraulic, System, Industrial battery, Main control, Valve, Mast repair, Fasteners, Schematics diagrams, Steering axle, Steering system, Wire harness repair And more)

[Click Here](#)

**Get all the content
after purchase**

**Thank you very
much.**

4. Check the thrust plates for wear or grooves. If the thrust plate is worn more than 0.05 mm (0.002 in), it must be replaced. Replace the thrust plate if it has grooves or holes. Dirty oil causes the thrust plate to wear near where the gears engage. Small holes on the outlet side the thrust plate are caused by cavitation. Lack of oil can also cause small holes in the thrust plates. If the color of the thrust plates has changed, the pump was too hot.

5. Inspect all the machined surfaces for scratches or damage. Remove with emery cloth any metal that is above the flat surface. Check the surfaces with a straight edge. Inspect the grooves for the seals for dirt or scratches.

6. Inspect the bearings for wear or damage. Replace the bearings if there is any small hole on the bearing surface. Replace the bushing if it is not round.

7. Look for damage on the seals. Replace all the seals and O-rings, even if they are in good condition. Look for cuts or changes in shape that can cause damage. Find out what damage caused the pump to fail. A damaged seal for the thrust plate can cause the shaft seal to leak. A damaged shaft seal can cause air to enter the hydraulic system.

8. Inspect the flow control valve and relief valve for dirt or scratches. Make sure the piston moves freely in the bore. Look at the poppet and seat for damage. The springs must not be broken or bent. Inspect the O-rings for damage. Make sure the orifices are open.

9. If any parts of the pump have damage from dirt in the oil, inspect the hydraulic tank. Drain the tank, clean the screen and tank, and replace the filter.

CAUTION

Do not permit dirty oil to enter the gear pump.

10. Inspect the inlet hose to the gear pump. Use a lamp to look inside the hose. Look for pieces of the rubber that are separating from the hose. Inspect the hose for restrictions at the bends. Check for loose fittings or damaged O-rings.

ASSEMBLY

1. Lubricate all parts with hydraulic oil before they are installed into the pump.

CAUTION

Make sure no dirt enters the pump during assembly.

2. Put Loctite 290® sealant around the outside of the front seal. Install the seal in the front cover. Make sure the seal is installed straight. If the pump has a ball bearing for the shaft, install it in the front cover. Install the snap rings.

3. Install the needle bearings into the front and rear covers. Use a press to push the bearings into position. Push on the end of the bearings that has the writing. If the pump has check valves, install them in the cover.

4. Install the seals for the thrust plate. Install the rubber seal with the lips away from the gears. Install the paper gasket against the rubber seal. The plastic gasket is installed between the paper gasket and the thrust plate. Install the thrust plate with the bronze side toward the gears.

CAUTION

Make sure the holes in the gaskets and seals are aligned with the hole in the output side of the pump. The pump will not operate correctly if the oil from the outlet chamber cannot flow to the thrust plate.

Some pumps have thrust plates with small grooves for the seals. The seals must be cut to the correct length. Cut two strips that are 5.5 mm (0.22 in) long from the seal strip. Put grease on the seals and install them in the grooves in the center of the thrust plate. Cut the thrust plate on the front cover. Hit the thrust plate with a plastic hammer to 0.8 mm (0.031 in) from the machined surface. Cut four strips 6 mm (0.25 in) from the seal strip. Push the strips into the slots in the thrust plate. Lightly hit the thrust plate against the machined surface. Use a sharp blade to cut the seals even with the edge of the thrust plate.

Install the seal that has a “W” shape and the spacer in the groove in the front cover. Do not bend the metal seal. Install the seal in the outer groove in the front cover. Install the bearing blocks in the same positions from which they were removed.

5. Install the gears and bearing blocks in the pump chamber housing. Make sure the gear housing is installed in the correct position. The small hole in some housings must be in the outlet chamber. The large channels in the inlet and outlet chambers must be toward the

rear cover. The arrow indicating the direction of rotation on the gear housing must be toward the front cover. Align the marks on the gear housing with the marks on the covers.

6. Put the connecting shaft in the drive gear shaft on the pumps with two pump chambers. Install the thrust plates and seals. Put the gears and pump chamber housing on the center bearing housing with the marks aligned.

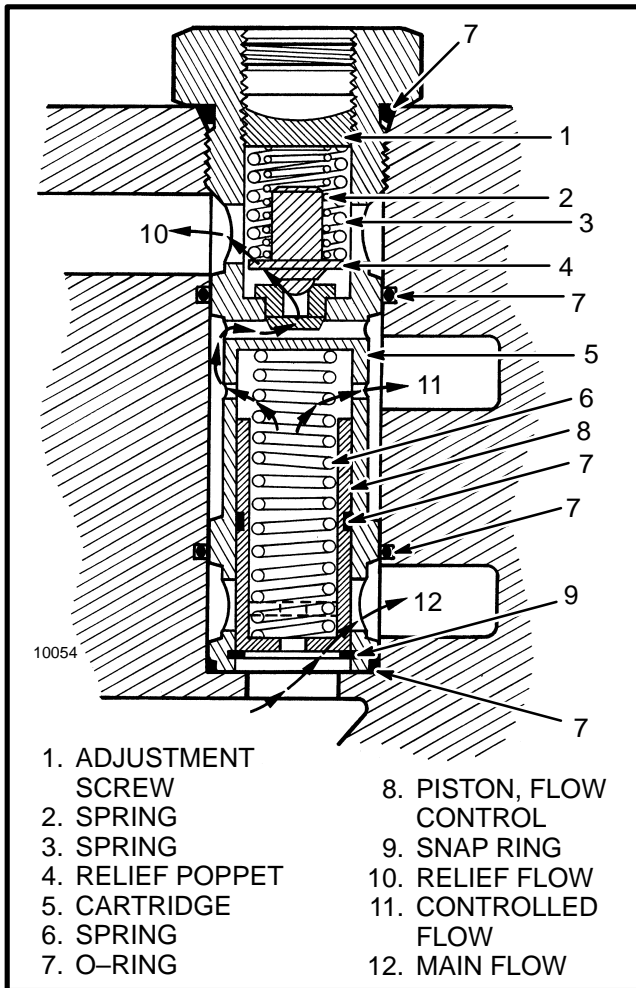

FIGURE 9. CARTRIDGE FOR THE FLOW CONTROL AND RELIEF VALVE

7. Install the seal and rear cover. Use a plastic hammer to join the sections. Apply a small amount of Loctite 290® sealant to the threads of the capscrews or studs. Install the capscrews or studs and tighten with your fingers. Rotate the drive shaft to make sure the pump is assembled correctly. Tighten the capscrews or nuts to the specification using an “X” sequence.

8. Use a soft blunt tool to install the O-rings in the bore of the flow and relief cartridge. Install the relief valve

and flow control valve. Install the fittings with new O-rings.

INSTALLATION

⚠ CAUTION

Before the gear pump is installed, loosen the lock nut on the adjustment screw for the relief valve. Loosen the adjustment screw until the spring is not compressed. If the relief valve was adjusted for a worn pump, the setting will not be correct for a new pump. Damage to the hydraulic system can occur if the setting of the relief valve is too high.

Always install a new filter when repairs are made to the hydraulic system. Drain and replace the hydraulic oil if the oil is dirty or burned.

1. Install a new gasket or O-ring on the front cover of the pump. Put a thin layer of Never-Seez® on the splines of the drive shaft. Fill the inlet port of the pump with hydraulic oil. Turn the drive shaft in the direction of rotation until oil comes out the outlet port.

2. Install the pump in the lift truck.

⚠ WARNING

Some of the pumps are very heavy. Use a lifting device to help install the pump.

3. Install and tighten the capscrews. Remove the caps from the fittings. Connect the hoses.

4. Remove the plug from the breather on the tank. Install the breather. Open the valve on the tank. Fill the tank with clean hydraulic oil.

⚠ CAUTION

Do not permit hot oil to enter a cold pump. Make sure the relief valve in each system is at the lowest setting.

5. Install a 0 to 20 MPa (0 to 3000 psi) pressure gauge to a tee fitting at the pump outlet port. Start the engine and run it at idle speed for three minutes.

⚠ CAUTION

Do not operate any valve until the pump has run for three minutes at low pressure and low speed.

6. Touch the pump with your hand. If the pump is hot, it has a problem. If the pump is not hot, then increase the

engine speed to the high limit. Momentarily increase the pressure to the relief setting. Repeat this procedure for 3 minutes.

7. Look at the pressure gauge and adjust the relief valve. See Checks And Adjustments for the lift truck for which you are making repairs.

CHECKS AND ADJUSTMENTS

CHECK THE OUTPUT OF THE PUMP

Two methods are given for checking the volume of flow from the hydraulic pump. The first method uses a flow meter, a pressure gauge, and a needle valve. The second method uses a needle valve, a pressure gauge, a container and a timer.

NOTE: If the pump has two outlet ports, do separate flow tests. Add the results of both tests to find the total output rate.

FIRST METHOD (See FIGURE 10.)

1. If the flow meter is available, install the flow meter between a needle valve and the outlet port of the pump. The pressure gauge must be between the needle valve and the pump. Make a separate check for each system if the pump is a tandem or if a flow regulator is part of the pump. When the hydraulic oil is at operating temperature, run the engine at 2800 RPM with no load on the hydraulic system. Note the reading of the flow meter. Compare the output rate of the pump with the specification found in the CAPACITIES AND SPECIFICATIONS section of the **SERVICE MANUAL**.

2. Run the engine at the high limit. Slowly close the needle valve until the gauge indicates a pressure just below the specification for the relief valve setting. The pump output at the high or pressure must be within 25% of the output with no load. If the output at high pressure is less than 75% of the low pressure output, the pump has a problem.

WARNING

Hydraulic oil can be hot. Do not touch the oil during the tests.

SECOND METHOD (See FIGURE 11.)

1. Another method of checking the pump output is to measure the amount of oil moved in a given amount of time. Run the engine until the oil is 55 to 65°C (130 to 150°F). Disconnect the line from the outlet port of the pump. Install a 0 to 20 MPa (0 to 3000 psi) pressure

gauge on a tee fitting connected to a hose from the outlet port. Install the needle valve on the end of the hose. Connect another hose to the needle valve. Put the other end of the hose in a container with a 18 litre (5 gallon) capacity. Make sure the reservoir is full.

CAUTION

This test must be done quickly to prevent the hydraulic tank from becoming empty. Do not operate the engine when there is no oil in the hydraulic tank.

2. The needle valve must be fully open. Start the engine and run the engine at its governed rpm for 5 seconds. Stop the engine. Measure the volume of oil that entered the container in 5 seconds. Multiply the quantity in the container by 12 to find the output per minute. Compare the pump output rate with the specifications found in the CAPACITIES AND SPECIFICATIONS section of the **SERVICE MANUAL**. The pump output rate must be within 20% of the specifications.

3. Start the engine and run the engine at its governed rpm. Close the needle valve until the pressure increases to just below the relief valve setting. Measure the volume of fluid the pump moves in 5 seconds. Compare this quantity with the results from the test of the pump output at low pressure. The output of the pump at high pressure must be within 25% of the volume of oil flow at low pressure.

CHECK FOR AIR IN THE HYDRAULIC SYSTEM

If the pump makes noise or does not move the correct amount of oil, check for air in the system. Run the engine until the oil is warm. Remove the filter head and look into the tank. If there are bubbles in the oil, air is in the hydraulic system. The most common place of entry of the air is in the inlet hose to the pump. Check for air leaks by pouring oil over the fittings and hose when the engine is running. If the noise decreases, the leak is in that area. See the Troubleshooting section for other causes of air in the hydraulic system.

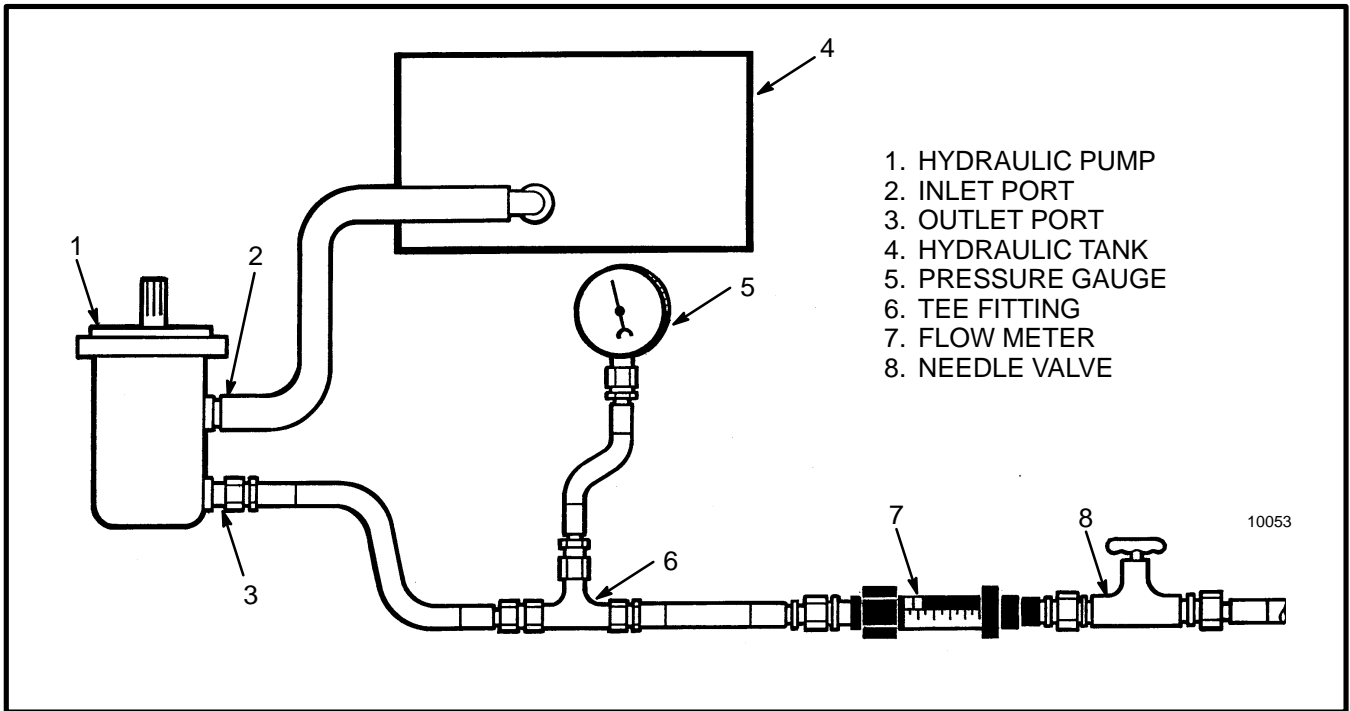

FIGURE 10. CHECK THE OUTPUT OF THE HYDRAULIC PUMP WITH A FLOW METER

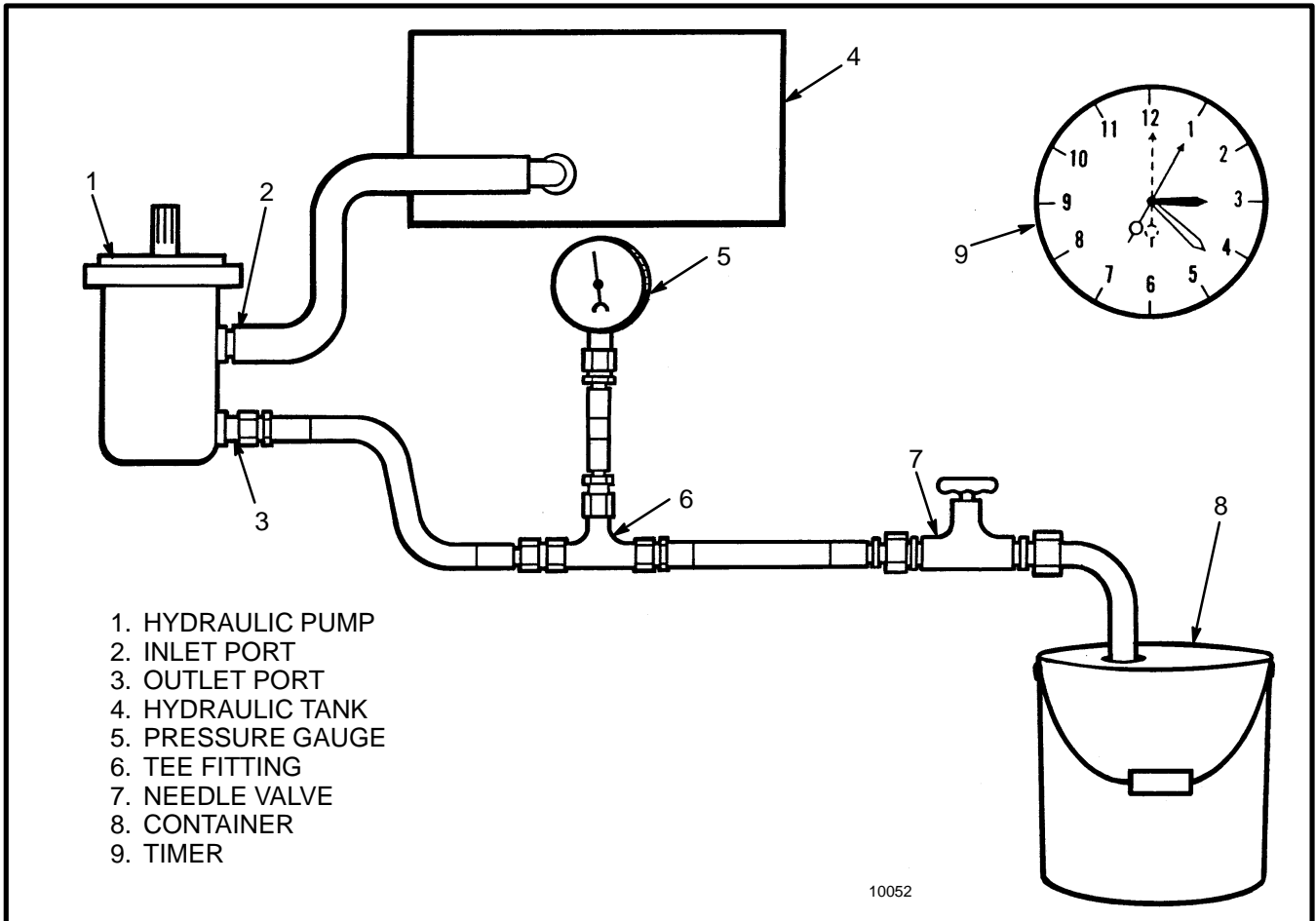

FIGURE 11. CHECK THE OUTPUT OF THE HYDRAULIC PUMP

TROUBLESHOOTING

PROBLEM	POSSIBLE CAUSE
The pump makes too much noise	<ul style="list-style-type: none"> Air in the hydraulic system The bearings or gears are damaged Outlet valve from the hydraulic tank is closed Low oil level in hydraulic tank Wrong oil Supply hose is twisted or has a restriction Breather on hydraulic tank has a restriction Seal for pump shaft is damaged Pump drive has a problem Relief valve is set wrong or is damaged Screen in hydraulic tank has a restriction Pump is loose or not installed correctly in its mount Engine speed too fast
Low hydraulic pressure	<ul style="list-style-type: none"> Relief valve is set wrong or is damaged Flow regulator valve is damaged Leak inside of a hydraulic cylinder Worn or damaged hydraulic pump Air in the hydraulic system Supply hose is twisted or has a restriction Low oil level in hydraulic tank Wrong oil Breather on hydraulic tank has a restriction Seal for pump shaft is damaged Pump drive has a problem Pump assembled wrong Screen in hydraulic tank has a restriction
Pump has leaks, loose fittings or damaged seals	<ul style="list-style-type: none"> Housing capscrews are loose Relief valve is damaged Pump housing is damaged Worn seals and pump shaft

TROUBLESHOOTING

PROBLEM	POSSIBLE CAUSE
Pump is too hot Relief valve is set wrong or is damaged	<ul style="list-style-type: none"> Flow regulator valve is damaged Leak inside of a hydraulic cylinder Worn or damaged hydraulic pump Air in the hydraulic system Supply hose is twisted or has a restriction Low oil level in hydraulic tank Wrong oil Breather on hydraulic tank has a restriction Pump drive has a problem Pump assembled wrong Screen in hydraulic tank has a restriction Replacement hydraulic hoses are wrong size
Hydraulic pump wears faster than normal	<ul style="list-style-type: none"> Dirt in the hydraulic system Wrong hydraulic oil Relief valve is set wrong or is damaged Cavitation from restriction in inlet hose Pump drive has a problem Pump drive is not correctly aligned Pump is not installed correctly in its mount Pump is operating too hot Engine speed is too fast
Air in the hydraulic system	<ul style="list-style-type: none"> Low oil level in hydraulic tank Leak in inlet hose Loose inlet fitting Breather on hydraulic tank has a restriction Supply hose is twisted or has a restriction Screen in hydraulic tank has a restriction Pump seal is damaged Check valve in pump is damaged Pump housing capscrews are loose Worn or damaged hydraulic pump

