



Service Manual

Chassis, Mast & Options

DP80N	T32C-10011-up
DP90N	T32C-60011-up

FOREWORD

This service manual is a guide for servicing Cat® Lift Trucks. For your convenience the instructions are grouped by systems as a ready reference.

Long productive life of your lift truck(s) depends on regular and proper servicing. Servicing consistent with what you will learn by reading this service manual. Read the respective sections of this manual carefully and familiarize yourself with all of the components before attempting to start a test, repair or rebuild job.

The descriptions, illustrations and specifications contained in this manual are for trucks with serial numbers in effect at the time of printing. Cat Lift Trucks reserves the right to change specifications or design without notice and without incurring obligation.

The trucks listed in this manual are powered by 6M60-TL diesel engine. For engine servicing, please refer to 6M60-TL diesel engine service manual Pub. No. 99709-61100.

Safety Related Signs

The following safety related signs are used in this service manual to emphasize important and critical instructions:



Indicates a specific potential hazard resulting in serious bodily injury or death.



Indicates a specific potential hazard resulting in bodily injury, or damage to, or destruction of, the lift truck.



Indicates a condition that can cause damage to, or shorten service life of, the lift truck.

SAFETY



Do not operate this truck unless you have read and understand the instructions in the OPERATION & MAINTENANCE MANUAL. Improper truck operation is dangerous and could result in injury or death.

The proper and safe lubrication and maintenance for this lift truck, recommended by Cat Lift Trucks, are outlined in the OPERATION & MAINTENANCE MANUAL for these trucks.

The serviceman or mechanic may be unfamiliar with many of the systems on this truck. This makes it important to use caution when performing service work. A knowledge of the system and/or components is important before the removal or disassembly of any component.

Because of the size of some of the truck components, the serviceman or mechanic should check the weights noted in this Manual. Use proper lifting procedures when removing any components.

Following is a list of basic precautions that should always be observed.

- (1) Read and understand all warning plates and decals on the truck before operating, lubricating or repairing the product.
- (2) Always wear protective glasses and protective shoes when working around trucks. In particular, wear protective glasses when pounding on any part of the truck or its attachments with a hammer or sledge. Use welders gloves, hood/goggles, apron and other protective clothing appropriate to the welding job being performed. Do not wear loose-fitting or torn clothing. Remove all rings from fingers when working on machinery.
- (3) Do not work on any truck that is supported only by lift jacks or a hoist. Always use blocks or jack stands to support the truck before performing any disassembly.



Improper performance of lubrication or maintenance procedures is dangerous and could result in injury or death. Read and understand the OPERATION & MAINTENANCE MANUAL before performing any lubrication or maintenance.

- (4) Lower the forks or other implements to the ground before performing any work on the truck. If this cannot be done, make sure the forks or other implements are blocked correctly to prevent them from dropping unexpectedly.
- (5) Use steps and grab handles (if applicable) when mounting or dismounting a truck. Clean any mud or debris from steps, walkways or work platforms before using. Always face truck when using steps, ladders and walkways. When it is not possible to use the designed access system, provide ladders, scaffolds, or work platforms to perform safe repair operations.
- (6) To avoid back injury, use a hoist when lifting components which weigh 23 kg (50 lb.) or more. Make sure all chains, hooks, slings, etc., are in good condition and are of the correct capacity. Be sure hooks are positioned correctly. Lifting eyes are not to be side loaded during a lifting operation.
- (7) To avoid burns, be alert for hot parts on trucks which have just been stopped and hot fluids in lines, tubes and compartments.
- (8) Be careful when removing cover plates. Gradually back off the last two bolts or nuts located at opposite ends of the cover or device and pry cover loose to relieve any spring or other pressure, before removing the last two bolts or nuts completely.
- (9) Be careful when removing filler caps, breathers and plugs on the truck. Hold a rag over the cap or plug to prevent being sprayed or splashed by liquids under pressure. The danger is even greater if the truck has just been stopped because fluids can be hot.
- (10) Always use tools that are in good condition and be sure you understand how to use them before performing any service work.
- (11) Reinstall all fasteners with same part number. Do not use a lesser quality fastener if replacements are necessary. Do not mix metric fasteners with standard nuts and bolts.
- (12) If possible, make all repairs with the truck parked on a level, hard surface. Block truck so it does not roll while working on or under truck.
- (13) Disconnect battery and discharge any capacitors (electric trucks) before starting to work on truck. Hang "Do not Operate" tag in the Operator's Compartment.
- (14) Repairs, which require welding, should be performed only with the benefit of the appropriate reference information and by personnel adequately trained and knowledgeable in welding procedures. Determine type of metal being welded and select correct welding proce-

-
- dure and electrodes, rods or wire to provide a weld metal strength equivalent at least to that of parent metal.
- (15) Do not damage wiring during removal operations. Reinstall the wiring so it is not damaged nor will it be damaged in operation by contacting sharp corners, or by rubbing against some object or hot surface. Do not connect wiring to a line containing fluid.
 - (16) Be sure all protective devices including guards and shields are properly installed and functioning correctly before starting a repair. If a guard or shield must be removed to perform the repair work, use extra caution.
 - (17) Always support the mast and carriage to keep carriage or attachments raised when maintenance or repair work is performed, which requires the mast in the raised position.
 - (18) Loose or damaged fuel, lubricant and hydraulic lines, tubes and hoses can cause fires. Do not bend or strike high pressure lines or install ones which have been bent or damaged. Inspect lines, tubes and hoses carefully. Do not check for leaks with your hands. Pin hole (very small) leaks can result in a high velocity oil stream that will be invisible close to the hose. This oil can penetrate the skin and cause personal injury. Use cardboard or paper to locate pin hole leaks.
 - (19) Tighten connections to the correct torque. Make sure that all heat shields, clamps and guards are installed correctly to avoid excessive heat, vibration or rubbing against other parts during operation. Shields that protect against oil spray onto hot exhaust components in event of a line, tube or seal failure, must be installed correctly.
 - (20) Relieve all pressure in air, oil or water systems before any lines, fittings or related items are disconnected or removed. Always make sure all raised components are blocked correctly and be alert for possible pressure when disconnecting any device from a system that utilizes pressure.
 - (21) Do not operate a truck if any rotating part is damaged or contacts any other part during operation. Any high speed rotating component that has been damaged or altered should be checked for balance before reusing.

HOW TO READ THIS MANUAL

Disassembly diagram (example)

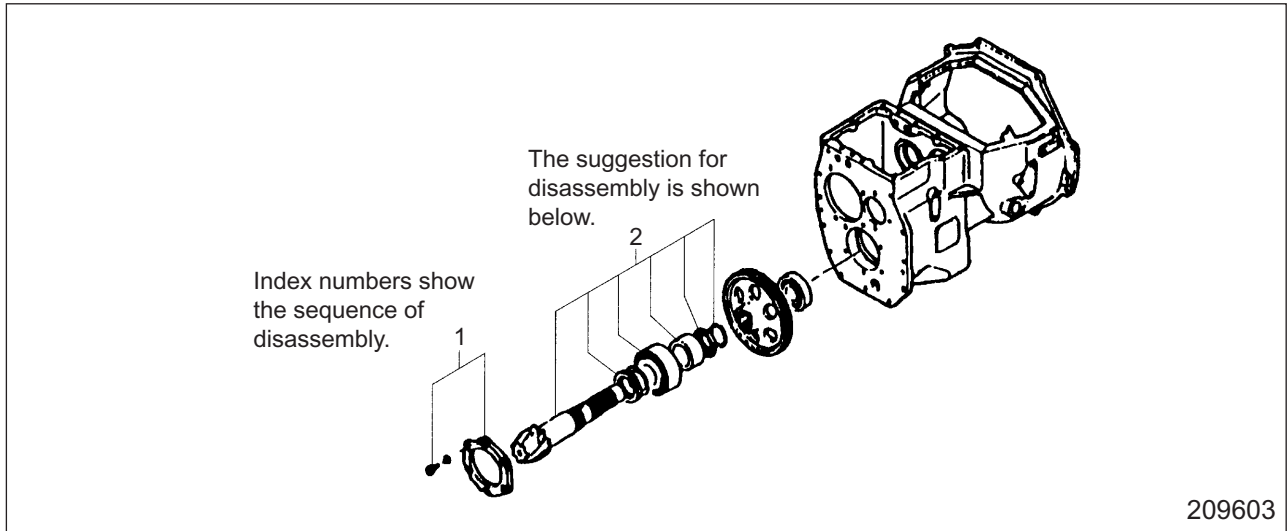

Sequence

- 1 Cover, Bolt, Washer (part name)
- 2 Output shaft (part name)

Suggestion for disassembly

- (1) Output shaft removal

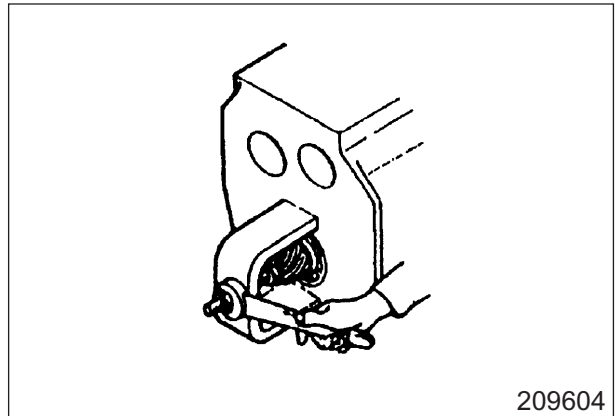

Symbols or abbreviations

- OP Option
- R1/4 Taper pipe thread (external) 1/4 inch (formerly PT1/4)
- Rc1/8 Taper pipe thread (internal) 1/8 inch (formerly PT1/8)
- G1/4A Straight pipe thread (external) 1/4 inch (formerly PF1/4-A)
- Rp1/8 Straight pipe thread (internal) 1/8 inch (formerly PS1/8)

Clearance between cylinder and piston	Standard valve	0.020 to 0.105 mm (0.00079 to 0.00413 in.)
	Repair service unit	0.15 mm (0.059 in.)

GROUP INDEX

GROUP INDEX	Items
GENERAL INFORMATION	Model View, Truck Models Covered, Serial Number Locations, Chassis and Mast Model Identification, Dimensions, Main Specifications
COOLING SYSTEM	Specifications, Structure, Removal and Installation, Inspection and Adjustment, Troubleshooting
ELECTRICAL SYSTEM	Specifications, Location of Components, Structure, Disassembly and Reassembly, Batteries and Charging, Troubleshooting, Electrical Wiring Diagram
CONTROLLER	Outline, Service Tool Functions, Error Code List, Troubleshooting
TILTABLE	Specifications, Structure, Oil supply, Hydraulic circuit diagram, Service Data
POWER TRAIN	Specifications, Structure, Reduction ratio, Removal and Installation of Engine and Transmission Unit
3-SPEED POWERSHIFT TRANSMISSION	Specifications, Description, Suggestions for Removal and Installation, Disassembly and Reassembly, Adjustment, Troubleshooting, Service Data
FRONT AXLE AND REDUCTION DIFFERENTIAL	Specifications, Structure, Suggestions for Removal and installation, Front Axle and Reduction Differential, Disassembly and Reassembly, Troubleshooting, Service Data
REAR AXLE	Specifications, Structure, Suggestions for Removal and Installation, Disassembly and Reassembly, Readjustment, Troubleshooting, Service Data
BRAKE SYSTEM	Specifications, Structure, Suggestions for Removal and Installation, Disassembly and Reassembly, Adjustment and Testing, Troubleshooting, Service Data
STEERING SYSTEM	Specifications, Structure, Procedure and Suggestions for Removal and Installation, Troubleshooting, Service Data
HYDRAULIC SYSTEM	Specifications, Structure, Suggestions for Removal and Installation, Gear Pump, Flow regulator valve, Down safety valve, Lift cylinder, Tilt cylinder, Inspection and Adjustment, Tests, Troubleshooting, Service Data
MASTS AND FORKS	Specifications, Structure, Suggestions for Removal and Installation, Mast assembly, Troubleshooting, Service Data
FORK POSITIONER	FORK POSITIONER (DP80N), Applicable Attachment Models, Specifications, Structure, Removal and installation, Troubleshooting, Service Data, FORK POSITIONER (DP90N) Applicable Attachment Models, Specifications, Structure, Removal and installation, Troubleshooting, Service Data
SERVICE DATA	Maintenance Chart, Tightening Torque of Standard Bolts, Lubrication Standards

1

2

3

4

5

6

7

8

9

10

11

12

13

14

15

GENERAL INFORMATION

1. Model View.....	1-2
2. Truck Models Covered	1-2
3. Serial Number Locations	1-3
4. Main specifications	1-4
5. Chassis and Mast Model Identification.....	1-5
6. Dimensions (Approximate).....	1-6

1. Model View

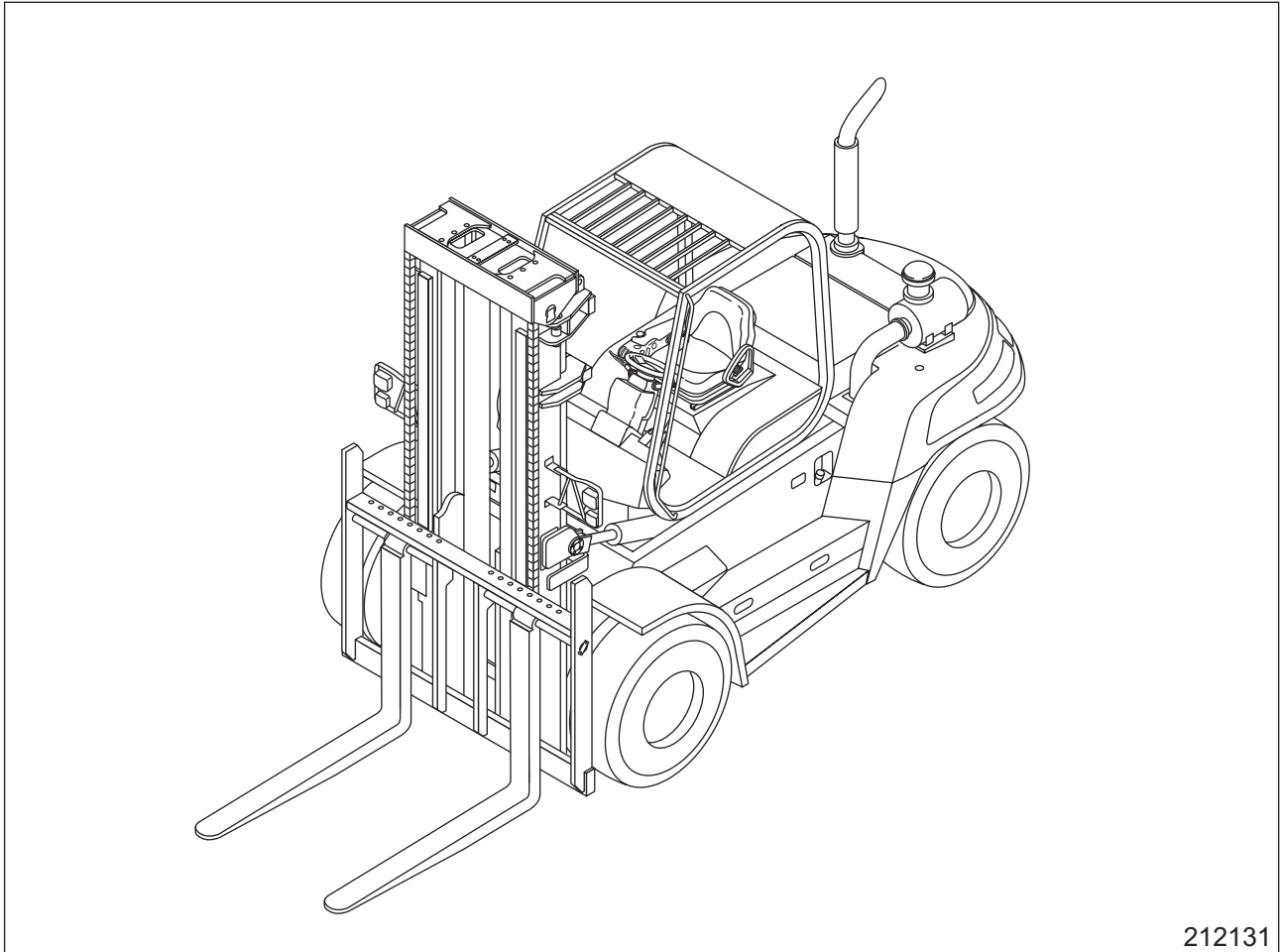

212131

2. Truck Models Covered

This Service Manual furnishes servicing and maintenance information for the following trucks:

Truck model	Transmission	Model code - Serial number	Engine mounted
DP80N	Powershift	T32C-10011-up	Mitsubishi 6M60-TL diesel engine
DP90N	Powershift	T32C-60011-up	Mitsubishi 6M60-TL diesel engine

3. Serial Number Locations

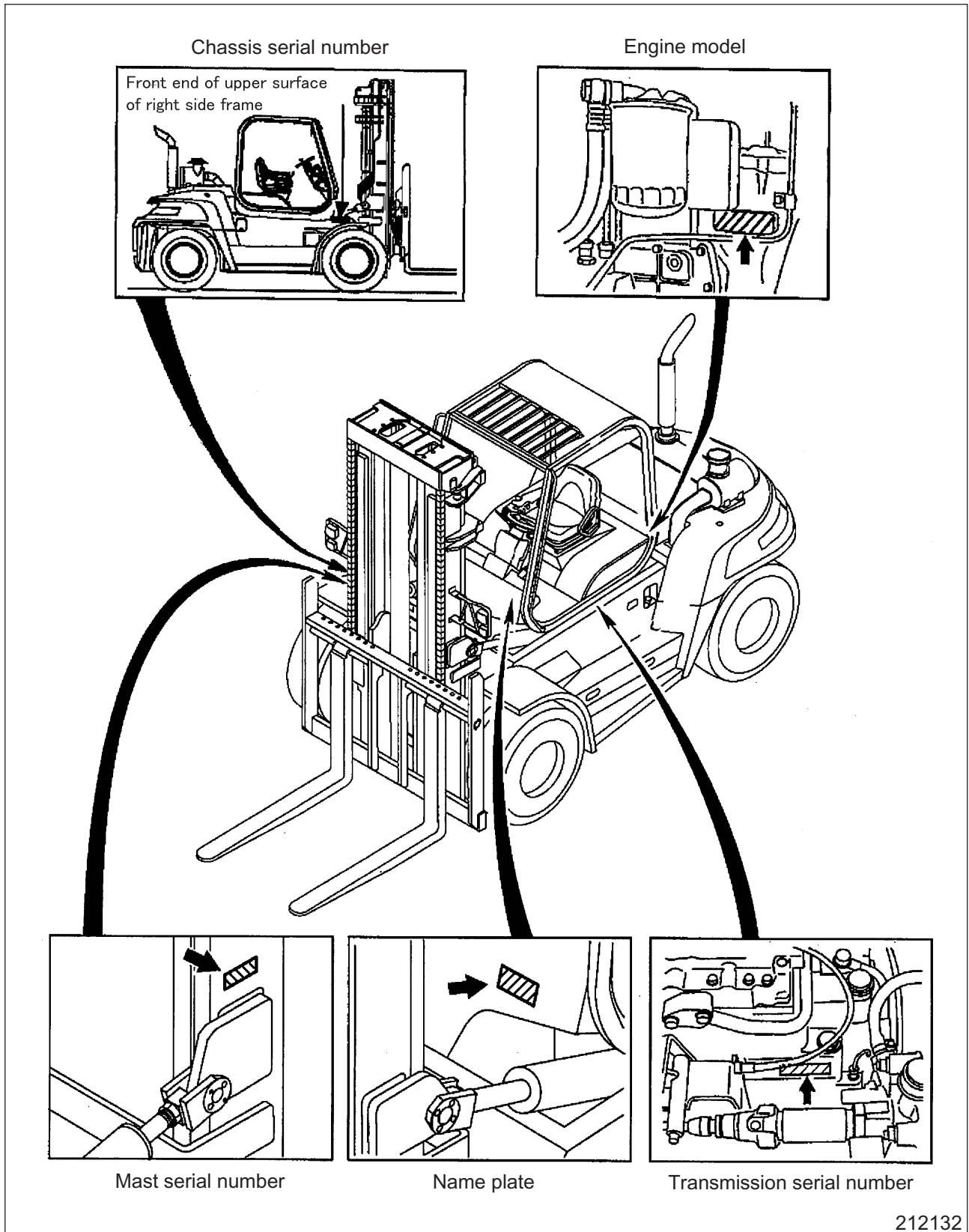

212132

4. Main specifications

Truck model		DP80N	DP90N	
Designation		Mitsubishi T32C		
Type		Standard (with 3-speed powershift transmission)		
General	Capacity/load center	8000/600 kgf/mm (17500/24 lbf/in.)	9000/600 kgf/mm (20000/24 lbf/in.)	
	Lift	3300 mm (130 in.)		
	Lift speed (unloaded/loaded)	530/500 mm/sec (104/98 fpm)	430/400 mm/sec (85/81 fpm)	
	Lowering speed (unloaded/loaded)	500 mm/sec (98 fpm)	400 mm/sec (79 fpm)	
	Tilt angle (forward-backward)	15°– 12°		
	Free lift	220 mm (8.7 in.)	0	
Performance	Travel speeds (unloaded/loaded)	Forward	34.0/28.0 km/h (21.1/17.4 mph)	33.0/27.0 km/h (20.5/16.8 mph)
		Reverse		
	Minimum turning radius	3740 mm (147 in.)	3835 mm (151 in.)	
	Turning angle	Inside	74°	
		Outside	48°25'	
	Minimum intersecting aisle	3300 mm (130 in.)	3400 mm (134 in.)	
	Gradeability (rated load)	At 1.6 km/h (1 mph)	43%	37%
At 2 km/h (1.2 mph)		38%	34%	
Tires	Size of tires (front and rear)	9.00-20-12PR (I)	9320 kg (20540 lb)	
	Inflation pressure of tires (front and rear)	650 kPa (6.6 kgf/cm ²) [94 psi]	750 kPa (7.7 kgf/cm ²) [94 psi]	
Weight and axle loading (unload)	Weight	11320 kg (25000 lb)	13060 kg (28800 lb)	
	Front axle loading	5310 kg (11700 lb)	6010 kg (13300 lb)	
	Rear axle loading	6010 kg (13300 lb)	7050 kg (15550 lb)	

5. Chassis and Mast Model Identification

[Chassis]

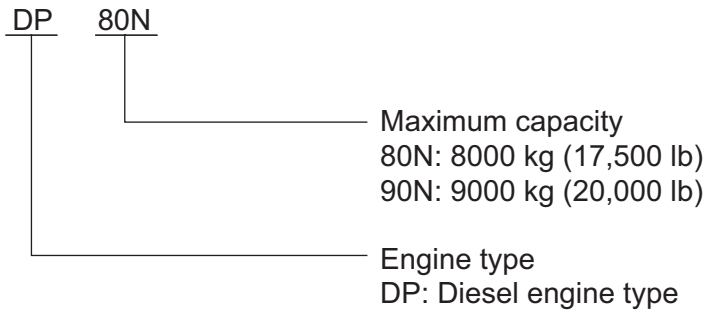

[Mast]

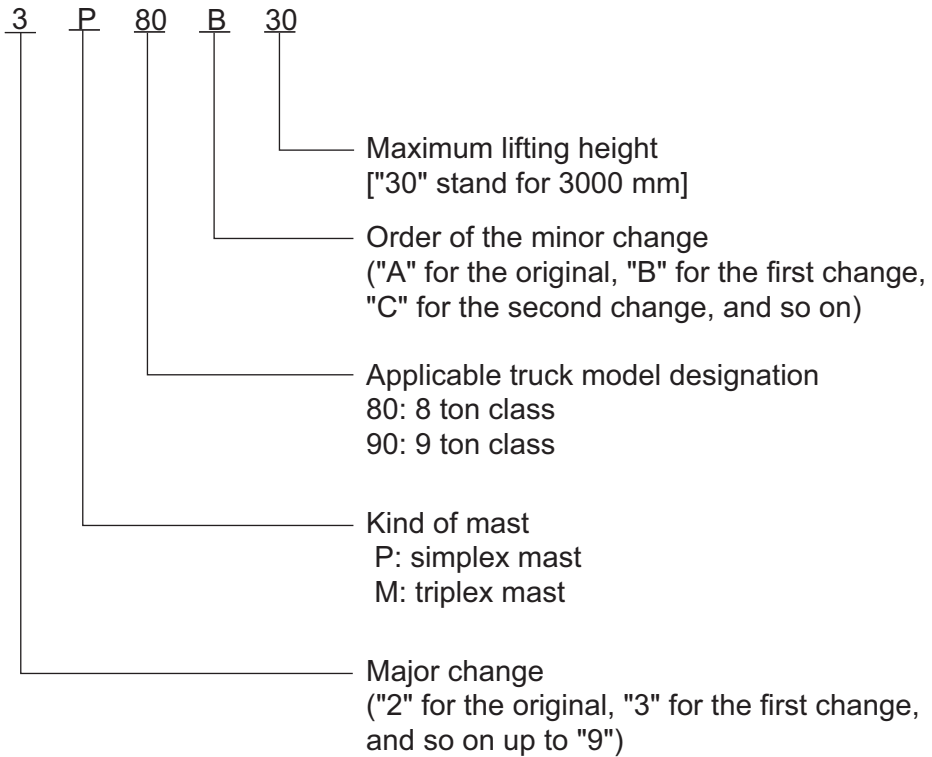

6. Dimensions (Approximate)

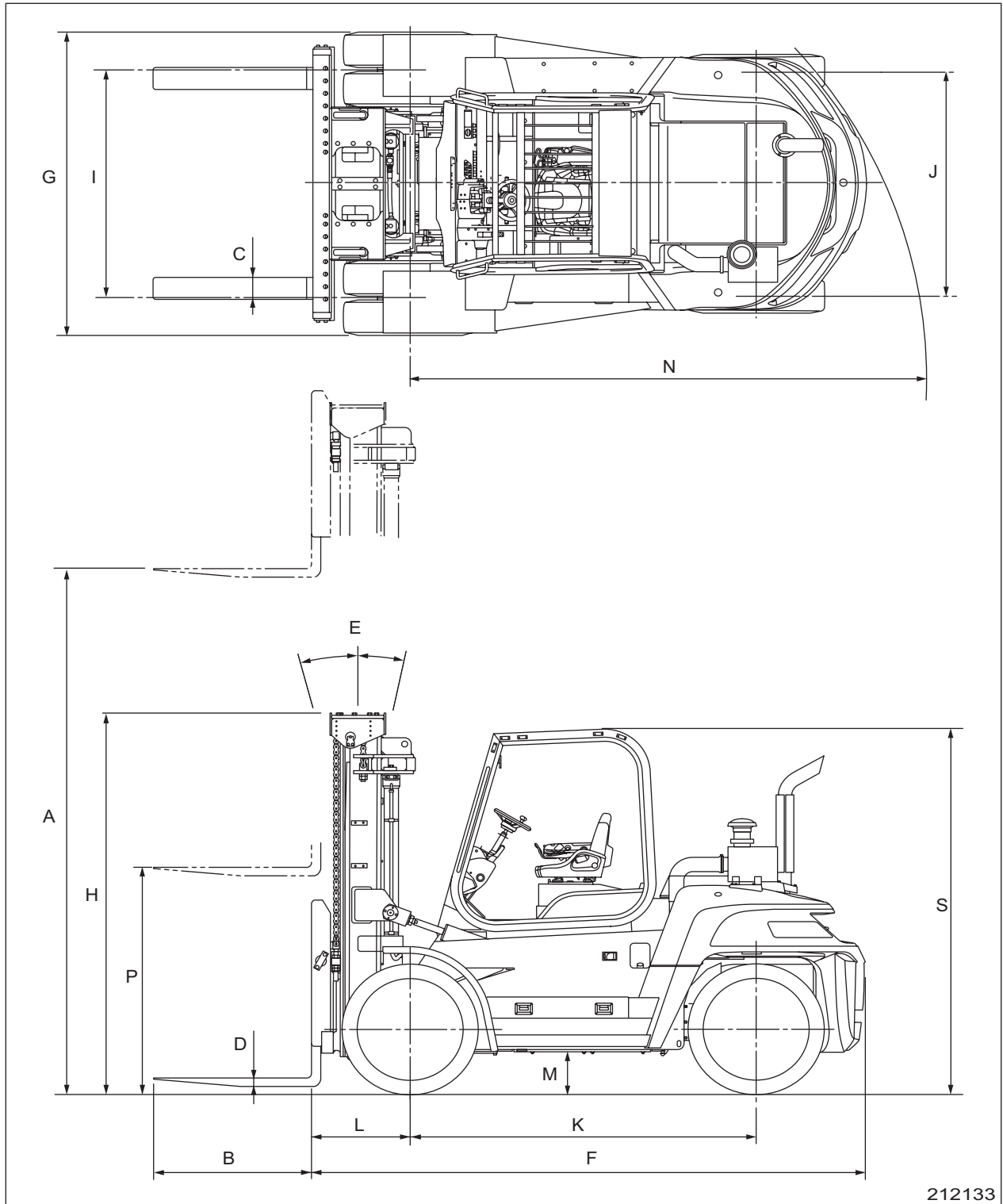

GENERAL INFORMATION

No.	Truck model		DP80N	DP90N
A	Lift	Simplex mast	3300 mm (130 in.)	
		Triplex mast	4580 mm (180.3 in.)	–
B	Fork length		1220 mm (48 in.)	
C	Fork width		180 mm (7.1 in.)	
D	Fork thickness		64 mm (2.5 in.)	72 mm (2.6 in.)
E	Tilt angle (forward-backward)	Simplex mast	15°–12°	
F		Triplex mast	6°–6°	–
G	Overall length		3390 mm (133 in.)	4170 mm (164 in.)
	Overall width (outside of tires)		2390 mm (94 in.)	
H	Overall height (to top of mast lowered)	Simplex mast	2295 mm (115 in.)	3120 mm (123 in.)
		Triplex mast	2295 mm (115 in.)	–
K	Tread (front)		1820 mm (72 in)	
L	Tread (rear)		1750 mm (69 in)	
K	Wheelbase		2580 mm (102 in)	
L	Front overhang	Simplex mast	670 mm (26 in.)	755 mm (30 in.)
		Triplex mast	725 mm (28.5 in.)	–
M	Ground clearance (at frame)		230 mm (9.1 in.)	
N	Minimum turning radius		3830 mm (151 in.)	3930 mm (155 in.)
P	Free lift (floor to fork top, Triplex mast)		1655 mm (65.5 in.)	–

COOLING SYSTEM

1. Specifications	2-2
2. Structure.....	2-3
3. Suggestions for Removal and Installation.....	2-4
3.1 Removing radiator and intercooler.....	2-4
3.1.1 Preparation.....	2-4
3.1.2 Removal sequence	2-4
3.1.3 Suggestions for Removal and Installation.....	2-5
3.1.4 Inspection and Repair	2-5
3.1.5 Installation	2-6
3.2 Procedure involving removal of radiator	2-8
3.2.1 Preparation.....	2-8
3.2.2 Removal sequence	2-8
3.2.3 Suggestions for Removal and Installation.....	2-9
3.2.4 Installation	2-9
3.3 Procedure involving removal of counterweight	2-10
3.3.1 Preparation.....	2-10
3.3.2 Removal sequence	2-10
3.3.3 Suggestions for Removal and Installation.....	2-11
3.3.4 Installation	2-11
4. Inspection and Adjustment.....	2-12
4.1 Inspection of Fan Belt	2-12
4.2 Fan Belt Tension Adjustment.....	2-12
5. Troubleshooting	2-13

1. Specifications

Truck model		DP80N	DP90N
Cooling system	Cooling method	Forced circulation of coolant	
	Radiator type	Corrugated fins with pressure cap	
	Coolant capacity	23 Liters (6.1 U.S. gal.)	
	Water pump type	Volute type, V-belt driven	
	Thermostat type	Wax pellet	

2. Structure

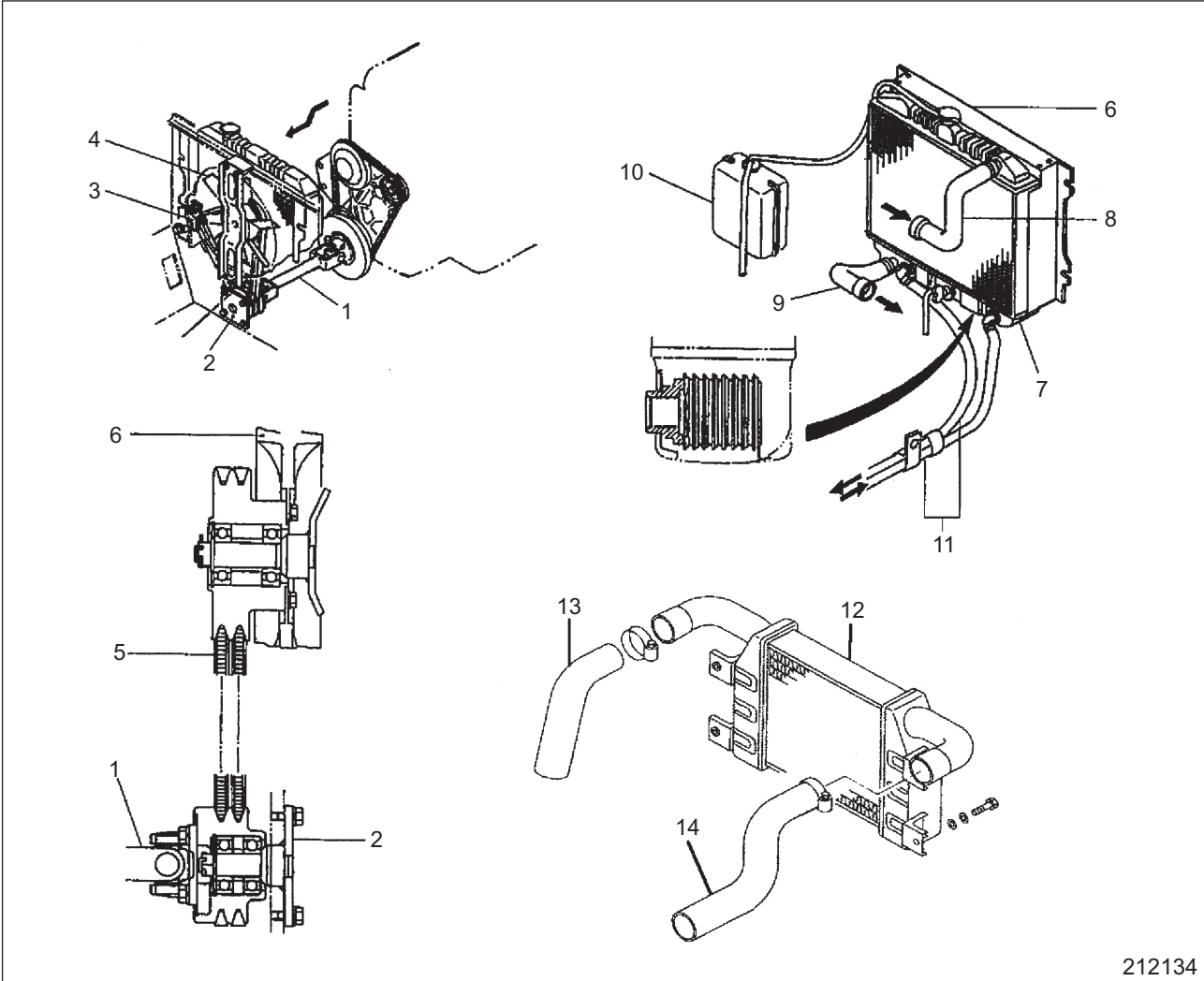

212134

- 1 Universal joint
- 2 Pulley boss
- 3 Tensioner pulley
- 4 Cooling fan
- 5 Fan belt
- 6 Radiator
- 7 Transmission oil cooler
- 8 Upper hose (radiator)
- 9 Lower hose (radiator)
- 10 Reserve tank
- 11 Transmission oil cooler hose
- 12 Intercooler
- 13 Upper hose (intercooler)
- 14 Lower hose (intercooler)

A reserve tank and a transmission oil cooler come standard on this cooling system. Fan belt adjustment is easy. An intercooler comes standard to cope with emission regulations of various countries of the world.

3. Suggestions for Removal and Installation

3.1 Removing radiator and intercooler

3.1.1 Preparation

- (1) Remove the engine cover and gas spring.
- (2) Open the drain cock to drain coolant from radiator.



Make sure the coolant temperature is not hot and the radiator cap is removed before opening the drain cock.

3.1.2 Removal sequence

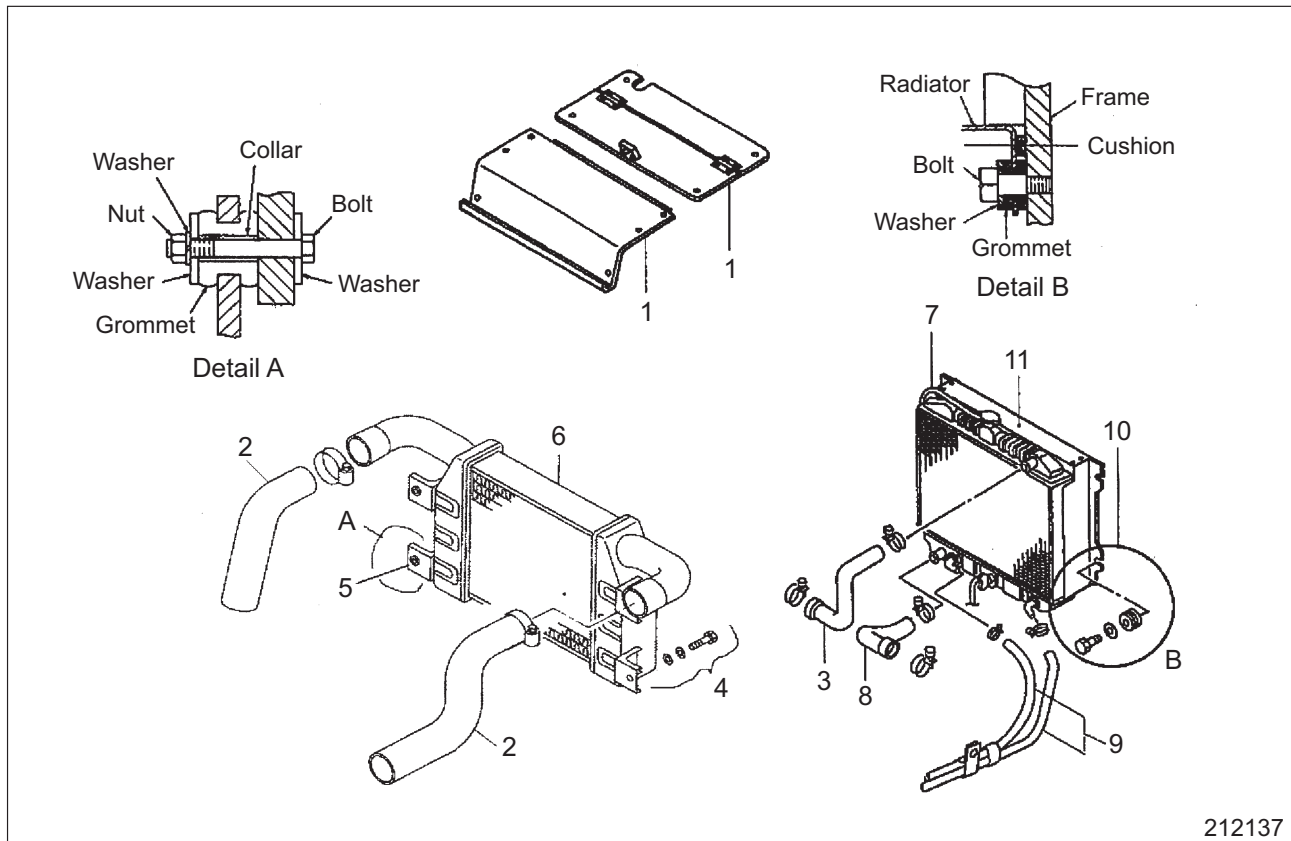

212137

- | | |
|--|---|
| 1 Radiator cover, Cover | 7 Reservoir tank hose |
| 2 Intercooler hoses (upper, lower) | 8 Radiator hose (lower) |
| 3 Radiator hose (upper) | 9 Transmission oil cooler hose |
| 4 Intercooler mount, Grommet, Collar, Washer, Bolt | 10 Radiator mount, Grommet, Washer, Cushion, Bolt |
| 5 Intercooler bracket | 11 Radiator |
| 6 Intercooler | |

3.1.3 Suggestions for Removal and Installation

(1) Intercooler

- (a) Attach a lifting hook through the top mounting bolt holes on the left hand and right hand of the intercooler brackets.
- (b) Hitch a rope to the hook and lift with a crane.

Weight of intercooler	9 kg (20 lb)
-----------------------	--------------

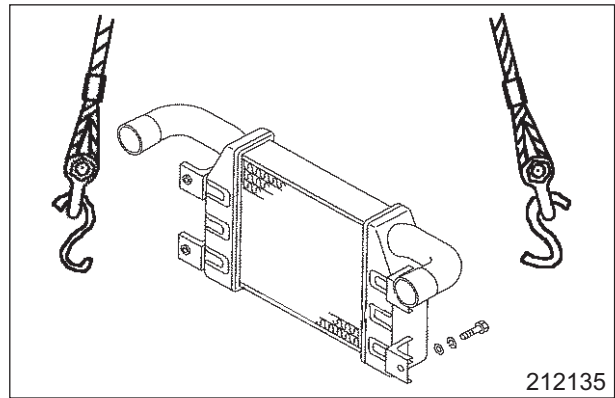

(2) Radiator

- (a) Support the radiator with crane.
- (b) Remove the radiator mounts (four places) and lift the radiator.

Weight of radiator	22.5 kg (50 lb)
--------------------	-----------------

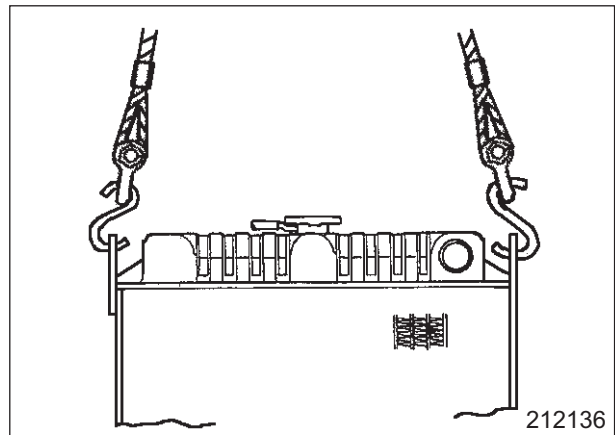

3.1.4 Inspection and Repair

(1) Intercooler

- (a) Replace any rubber mount which is inelastic or hardened.
- (b) When foreign matters, such as insects and dust, have been adhered to the fins of the core, blow them out with compressed air from the opposite side and remove them, taking care not to damage the fins.
Wear goggles for the sake of safety.
- (c) Replace the intercooler, if the corrosion and rusting are remarkable or the fin is not repairable.
- (d) Check the intercooler hoses (upper, lower) for bulge, damage to the hose clamp sections. Replace them if any abnormality is found.

BUY NOW

**Then Instant Download
the Complete Manual
Thank you very much!**