

# Service Manual

---

## **DP80, DP90 Chassis & Mast**

---

**DP80**      **T32B-00011-49999**

**DP90**      **T32B-50001-99999**

## FOREWORD

This service manual is a guide to servicing of Caterpillar® Lift Trucks of 8-ton and 9-ton models. The instructions are grouped by systems to serve the convenience of your ready reference.

Long productive life of your lift trucks depends to a great extent on correct servicing – the servicing consistent with what you will learn from this service manual. We hope you read the respective sections of this manual carefully and know all the components you will work on before attempting to start a test, repair or rebuild job.

The descriptions, illustrations and specifications contained in this manual were of the trucks of serial numbers in effect at the time it was approved for printing. Caterpillar reserves the right to change specifications or design without notice and without incurring obligation.

These lift trucks are powered by Mitsubishi 6D16 diesel engine. For the items of the engine, refer to the following service manual:

6D16 Diesel Engine Service Manual (Pub. No. 99709-58100)

### Safety Related Signs

The following safety related signs are used in this service manual to emphasize important and critical instructions:



Indicates a specific potential hazard resulting in serious bodily injury or death.



Indicates a specific potential hazard resulting in bodily injury, or damage to, or destruction of, the machine.

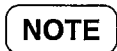

Indicates a condition that can cause damage to, or shorten service life of, the machine.

## WARNING

### SAFETY

#### WARNING

The proper and safe lubrication and maintenance for this lift truck, recommended by Mitsubishi, are outlined in the OPERATION & MAINTENANCE MANUAL for these trucks.

Improper performance of lubrication or maintenance procedures is dangerous and could result in injury or death. Read and understand the OPERATION & MAINTENANCE MANUAL before performing any lubrication or maintenance.

The serviceman or mechanic may be unfamiliar with many of the systems on this truck. This makes it important to use caution when performing service work. A knowledge of the system and/or components is important before the removal or disassembly of any component.

Because of the size of some of the truck components, the serviceman or mechanic should check the weights noted in this Manual. Use proper lifting procedures when removing any components.

Following is a list of basic precautions that should always be observed.

1. Read and understand all warning plates and decals on the truck before operating, lubricating or repairing the product.
2. Always wear protective glasses and protective shoes when working around trucks. In particular, wear protective glasses when pounding on any part of the truck or its attachments with a hammer or sledge. Use welders gloves, hood/goggles, apron and other protective clothing appropriate to the welding job being performed. Do not wear loose-fitting or torn clothing. Remove all rings from fingers when working on machinery.
3. Do not work on any truck that is supported only by lift jacks or a hoist. Always use blocks or jack stands to support the truck before performing any disassembly.

4. Lower the forks or other implements to the ground before performing any work on the truck. If this cannot be done, make sure the forks or other implements are blocked correctly to prevent them from dropping unexpectedly.

#### WARNING

Do not operate this truck unless you have read and understand the instructions in the OPERATION & MAINTENANCE MANUAL. Improper truck operation is dangerous and could result in injury or death.

5. Use steps and grab handles (if applicable) when mounting or dismounting a truck. Clean any mud or debris from steps, walkways or work platforms before using. Always face truck when using steps, ladders and walkways. When it is not possible to use the designed access system, provide ladders, scaffolds, or work platforms to perform safe repair operations.
6. To avoid back injury, use a hoist when lifting components which weigh 23 kg (50 lb.) or more. Make sure all chains, hooks, slings, etc., are in good condition and are of the correct capacity. Be sure hooks are positioned correctly. Lifting eyes are not to be side loaded during a lifting operation.
7. To avoid burns, be alert for hot parts on trucks which have just been stopped and hot fluids in lines, tubes and compartments.
8. Be careful when removing cover plates. Gradually back off the last two bolts or nuts located at opposite ends of the cover or device and pry cover loose to relieve any spring or other pressure, before removing the last two bolts or nuts completely.
9. Be careful when removing filler caps, breathers and plugs on the truck. Hold a rag over the cap or plug to prevent being sprayed or splashed by liquids under pressure. The danger is even greater if the truck has just been stopped because fluids can be hot.

10. Always use tools that are in good condition and be sure you understand how to use them before performing any service work.
11. Reinstall all fasteners with same part number. Do not use a lesser quality fastener if replacements are necessary. Do not mix metric fasteners with standard nuts and bolts.
12. If possible, make all repairs with the truck parked on a level, hard surface. Block truck so it does not roll while working on or under truck.
13. Disconnect battery and discharge any capacitors (electric trucks) before starting to work on truck. Hang "Do not Operate" tag in the Operator's Compartment.
14. Repairs, which require welding, should be performed only with the benefit of the appropriate reference information and by personnel adequately trained and knowledgeable in welding procedures. Determine type of metal being welded and select correct welding procedure and electrodes, rods or wire to provide a weld metal strength equivalent at least to that of parent metal.
15. Do not damage wiring during removal operations. Reinstall the wiring so it is not damaged nor will it be damaged in operation by contacting sharp corners, or by rubbing against some object or hot surface. Do not connect wiring to a line containing fluid.
16. Be sure all protective devices including guards and shields are properly installed and functioning correctly before starting a repair. If a guard or shield must be removed to perform the repair work, use extra caution.
17. Always support the mast and carriage to keep carriage or attachments raised when maintenance or repair work is performed, which requires the mast in the raised position.
18. Loose or damaged fuel, lubricant and hydraulic lines, tubes and hoses can cause fires. Do not bend or strike high pressure lines or install ones which have been bent or damaged. Inspect lines, tubes and hoses carefully. Do not check for leaks with your hands. Pin hole (very small) leaks can result in a high velocity oil stream that will be invisible close to the hose. This oil can penetrate the skin and cause personal injury. Use cardboard or paper to locate pin hole leaks.
19. Tighten connections to the correct torque. Make sure that all heat shields, clamps and guards are installed correctly to avoid excessive heat, vibration or rubbing against other parts during operation. Shields that protect against oil spray onto hot exhaust components in event of a line, tube or seal failure, must be installed correctly.
20. Relieve all pressure in air, oil or water systems before any lines, fittings or related items are disconnected or removed. Always make sure all raised components are blocked correctly and be alert for possible pressure when disconnecting any device from a system that utilizes pressure.
21. Do not operate a truck if any rotating part is damaged or contacts any other part during operation. Any high speed rotating component that has been damaged or altered should be checked for balance before reusing.

## HOW TO READ THIS MANUAL

### 1. Service data in the text

Example:

A: Standard value    B: Repair or service limit

Unit: mm (in.)

Clearance between cylinder and piston	A	0.020 to 0.105 (0.00079 to 0.00413)
	B	0.15 (0.0059)

### 2. Symbols or abbreviations

OP ..... Option

R1/4 ..... Taper pipe thread (external) 1/4 inch (formerly PT1/4)

Rc1/8 ..... Taper pipe thread (internal) 1/8 inch (formerly PT1/8)

G1/4A ..... Straight pipe thread (external) 1/4 inch (formerly PF1/4-A)

Rp1/8 ..... Straight pipe thread (internal) 1/8 inch (formerly PS1/8)

## Model View

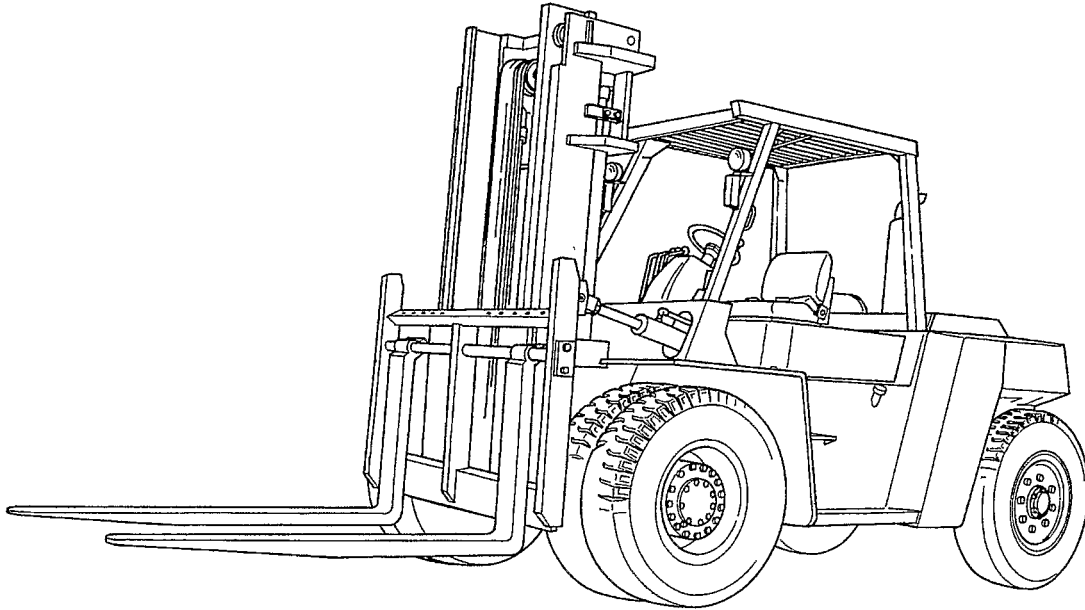

101706A

## Truck Models Covered

This Service Manual furnishes servicing and maintenance information for the following trucks:

Truck model	Transmission	Designation – Serial number	Engine mounted
DP80	Powershift	T32B – 00011- 49999	Mitsubishi 6D16 diesel engine
DP90	Powershift	T32B – 50001- 99999	Mitsubishi 6D16 diesel engine

## Serial Number Locations

Diesel engine serial number

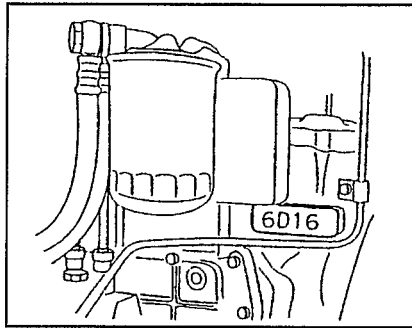

Chassis serial number

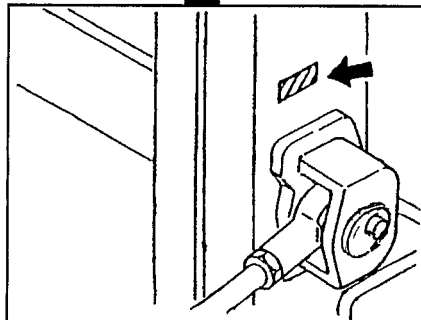
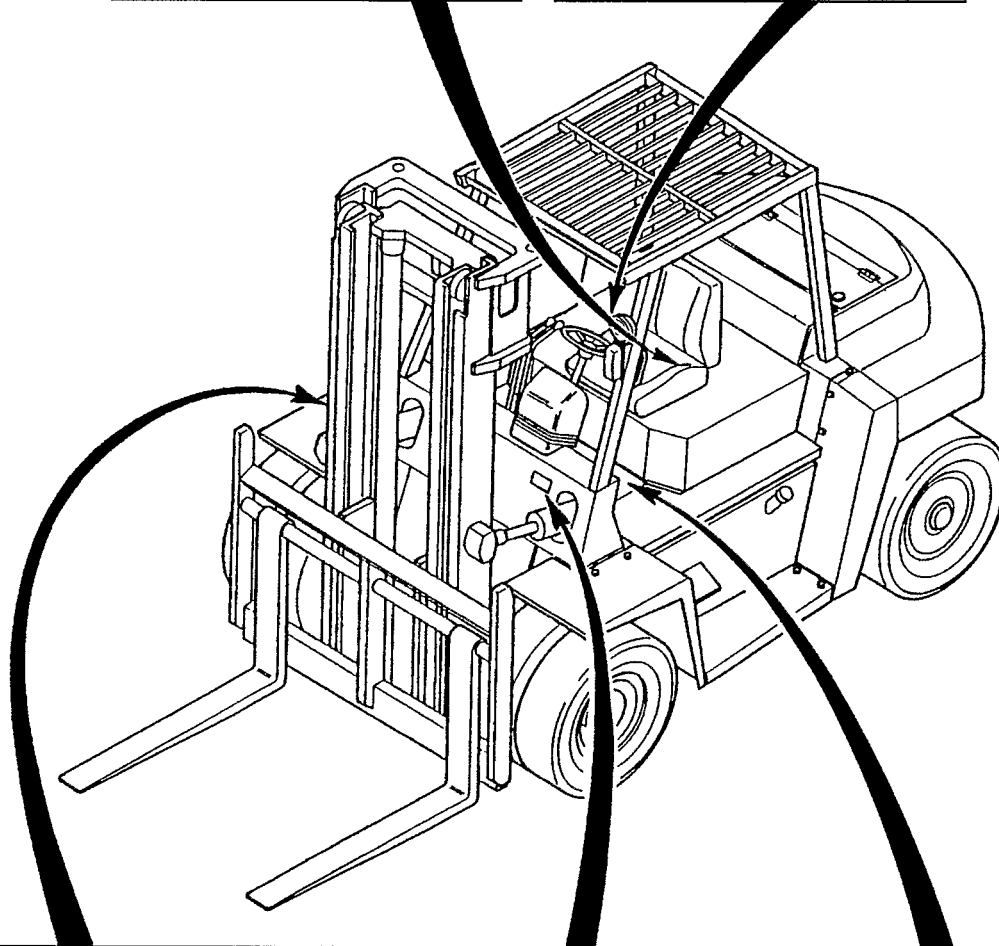
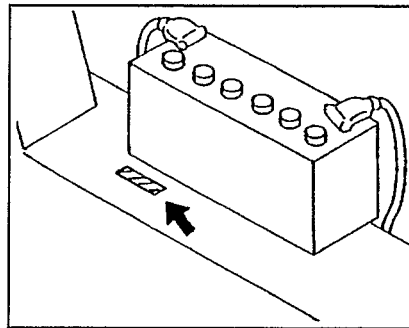

Mast serial number

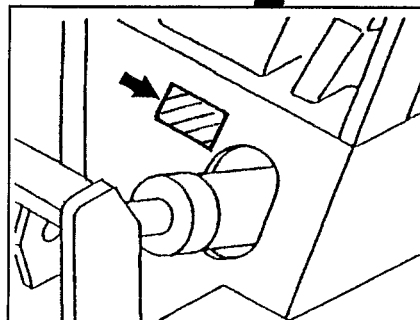

Name plate

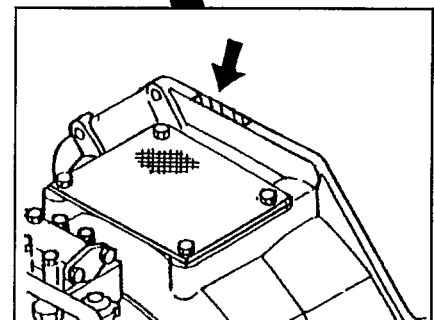

Transmission serial number

**Technical Data**

Truck Model		DP80	DP90	
Item				
Designation		T32B		
Type		Standard (with 3-speed powershift transmission)		
General	Capacity/load center kgf/mm (lbf/in.)	8000/600 (17500/24)	9000/600 (20000/24)	
	Lift mm (in.)	3300 (130)		
	Lift speed (unloaded/loaded) mm/sec (fpm)	530/500 (104/98)	430/410 (85/81)	
	Lowering speed (unloaded/loaded) mm/sec (fpm)	500 (98)	400 (79)	
	Tilt angle (forward – backward)	15° – 10°		
	Free lift mm (in.)	220 (8.7)	0	
Performance	Travel speeds (unloaded/ loaded) km/h (mph)	Forward	33.5/33.5 (20.8/20.8)	33.0/33.0 (20.5/20.5)
		Reverse		
	Minimum turning radius mm (in.)	3740 (147)	3835 (151)	
	Turning angle	Inside	74°	
		Outside	48°25'	
	Minimum intersecting aisle mm (in.)	3300 (130)	3400 (134)	
	Gradeability (rated load)	At 1.6 km/h (1 mph)	43 %	37 %
At 2 km/h (1.2 mph)		38 %	34 %	
Tires	Size of tires (front and rear)	9.00-20-12PR (I)	9.00-20-14PR (I)	
	Inflation pressure of tires (front and rear) kPa (kgf/cm <sup>2</sup> ) [psi]	640 (6.5) [92]	690 (7) [100]	
Weight and axle loading (unloaded)	Weight kg (lb)	11380 (25090)	13190 (29080)	
	Front axle loading kg (lb)	5420 (11950)	6200 (13670)	
	Rear axle loading kg (lb)	5960 (13140)	6990 (15410)	



**Dimensions (Approximate)**

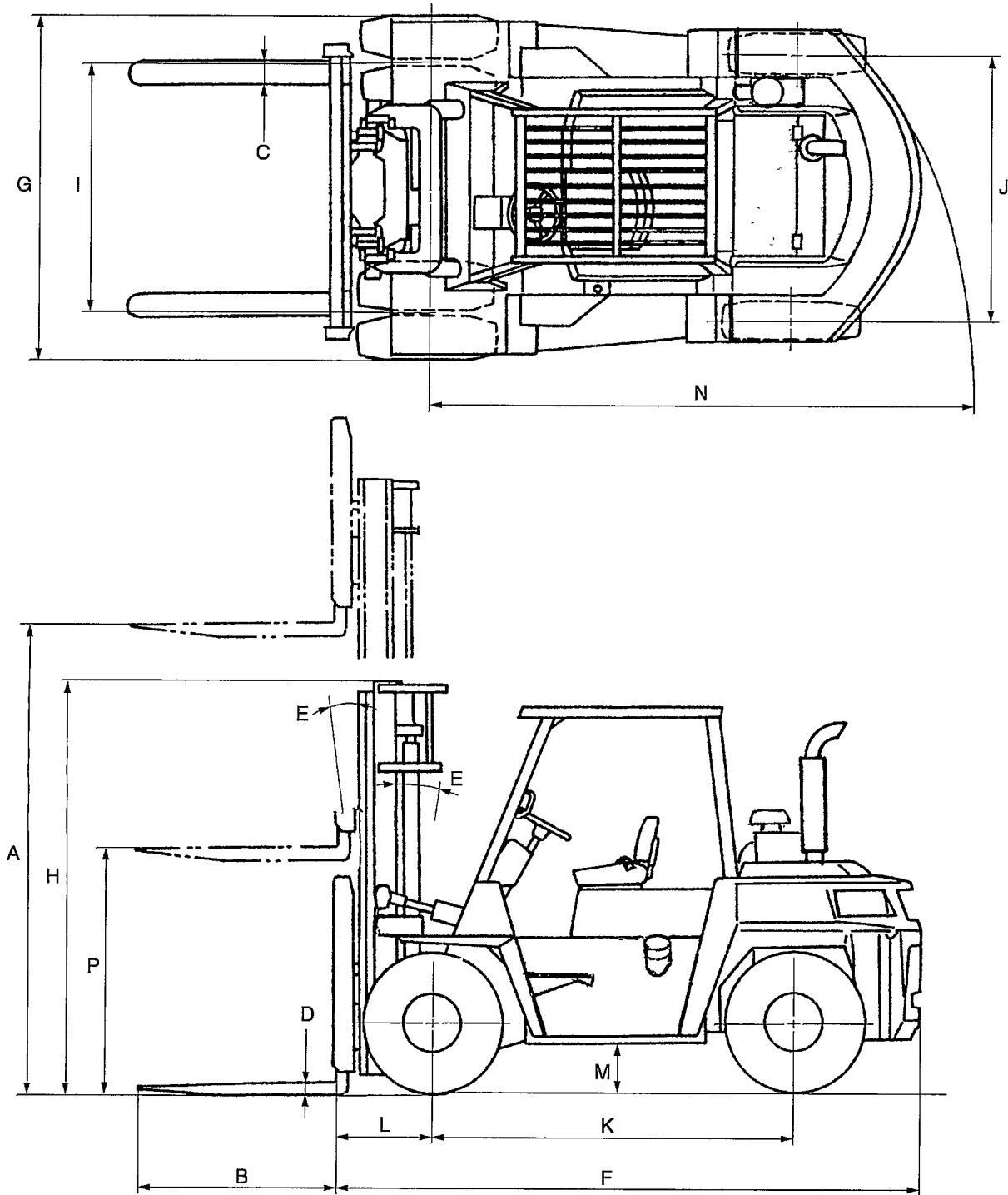

205523C

GENERAL INFORMATION

Unit: mm (in.)

Ref. No.	Truck Model		DP80	DP90
	Item			
A	Lift	Simplex mast	3300 (130)	
		Triplex mast	4700 (185)	–
B	Fork length		1220 (48)	
C	Fork width		180 (7.1)	
D	Fork thickness		60 (2.4)	70 (2.8)
E	Tilt angle (forward – backward)	Simplex mast	15° – 10°	
		Triplex mast	6° – 6°	–
F	Overall length		4000 (157)	4170 (164)
G	Overall width (outside of tires)		2390 (94)	
H	Overall height (to top of mast lowered)	Simplex mast	2925 (115)	3120 (123)
		Triplex mast	2925 (115)	–
I	Tread (front)		1820 (72)	
J	Tread (rear)		1750 (69)	
K	Wheelbase		2580 (102)	
L	Front overhang	Simplex mast	670 (26)	755 (30)
		Triplex mast	725 (28.5)	–
M	Ground clearance (at frame)		305 (12)	
N	Minimum turning radius		3740 (147)	3835 (151)
P	Free lift (floor to fork top, Triplex mast)		1665 (65.5)	–

## Specifications

Item		Truck Model	
		DP80	DP90
Battery	Model nomenclature – No. of batteries	95E41R – 2	
	Voltage	V	12
	Capacity	Ah	100
Transmission shift lever		Electric	
Console box		With OK monitor	
Automatic transmission controller		Electronic Control Unit (ECU)	
Starter switch		Anti-restart type	
Lamps		See “Lamp Bulb Specifications”.	

## Location of Components

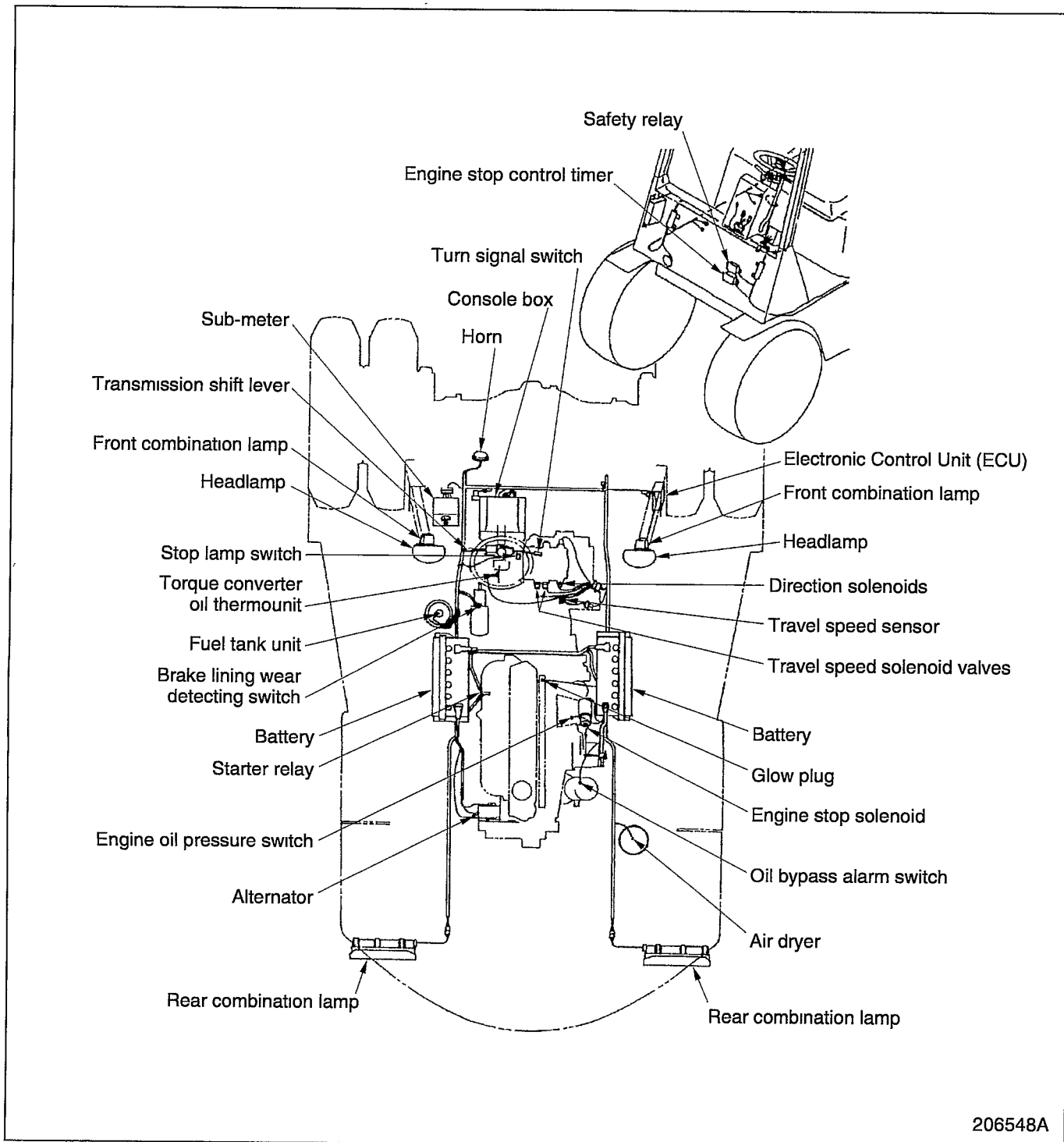

**CAUTION**

Clamp the harnesses away from moving parts or sharp edges. Repair a frayed harnesses with vinyl tape.

## Description

### Console Box

1. Engine coolant temperature gauge
2. Travel speed select switch
3. Fuel gauge
4. Service hourmeter
5. OK monitor
6. Starter switch
7. Lighting switch
8. Fuse box

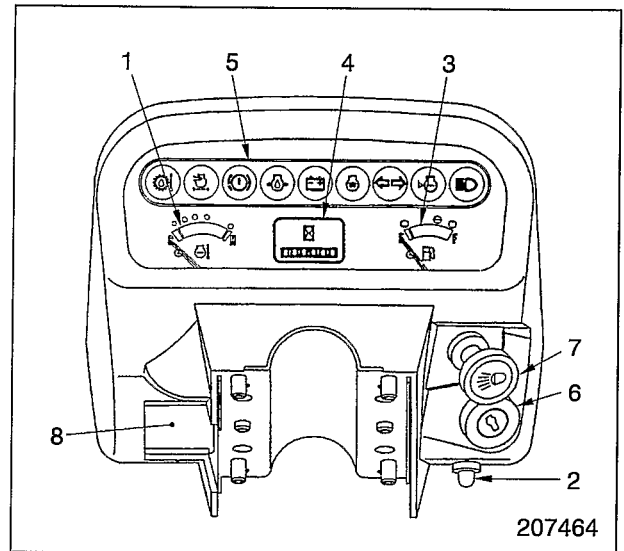

### OK Monitor

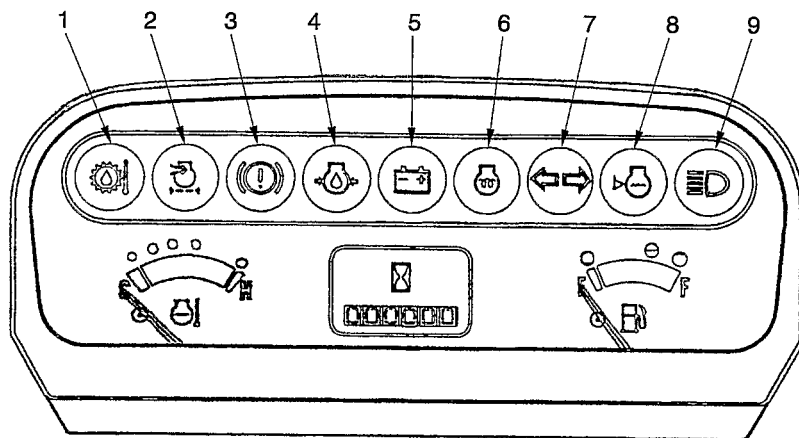

207465

### Function

No.	Indicator light	OFF	ON or flickering	Remarks
1	Powershift transmission oil temp. indicator light	Normal	Overheating	
2	Air cleaner element indicator light	Normal	Clogged	Option
3	Brake fluid level indicator light	Normal	Low	
4	Engine oil pressure indicator light	Normal	Low	
5	Alternator not charging indicator light	Normal	Abnormal	
6	Glow plug indicator light	Heating completed	Heating	
7	Turn signal indicator light		Turn signal ON	
8	Engine coolant level indicator light	Normal	Low	Option
9	Headlamp beam indicator light	Low	High	Option

### How to check indicator light bulbs

The bulbs are normal if the indicator lights 1, 2, 3 and 8 come ON when the starter switch key is turned to I (ON) position. (The indicator lights will go OFF when the engine starts.)

Components

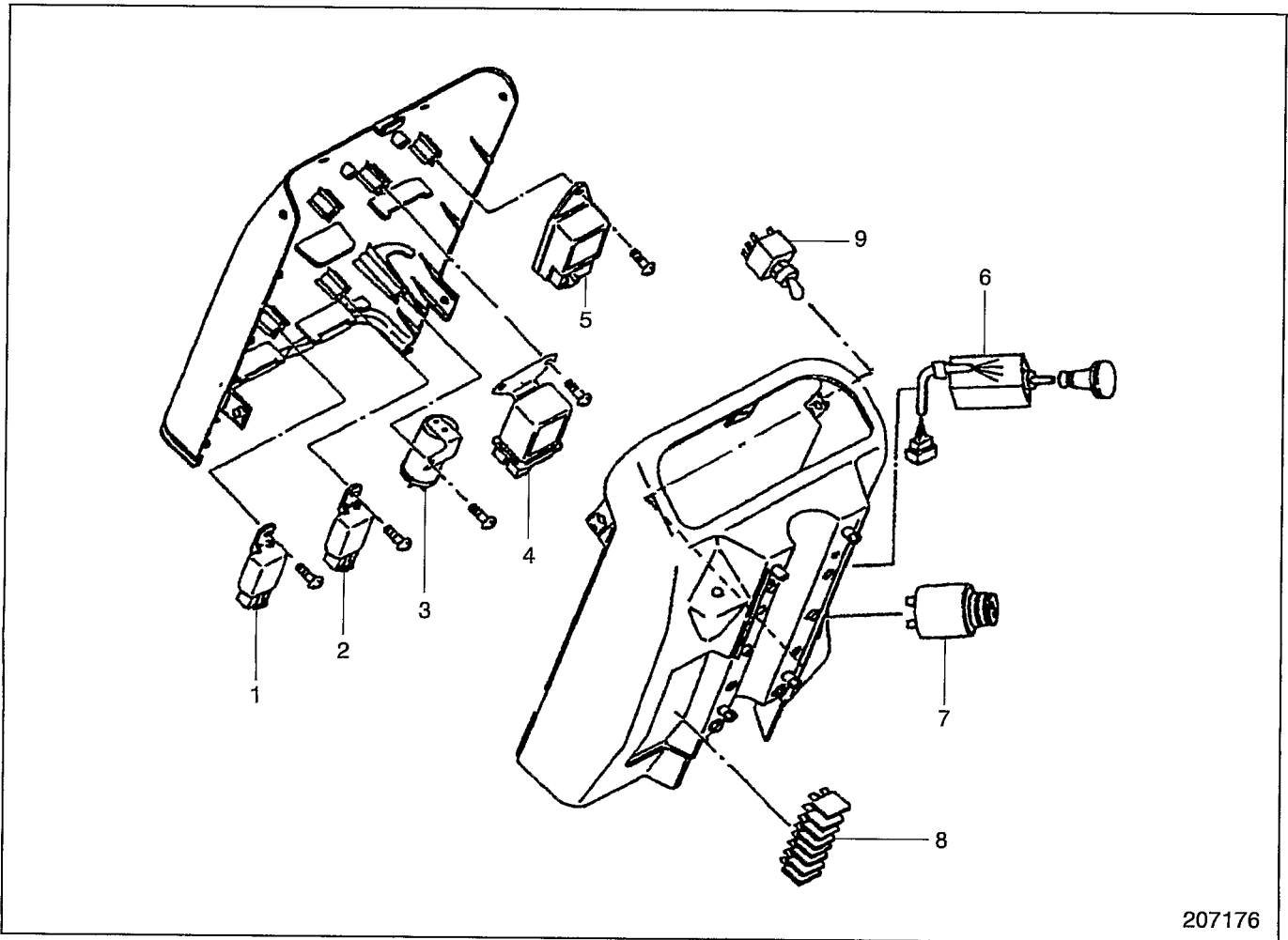

207176

- 1. Power relay
- 2. Power relay
- 3. Turn signal relay
- 4. Glow plug relay
- 5. Glow plug timer

- 6. Lighting switch
- 7. Starter switch
- 8. Fuses
- 9. Travel speed select switch

Sub-Meter

- 1. Air pressure gauge
- 2. Brake lining warning light (red)

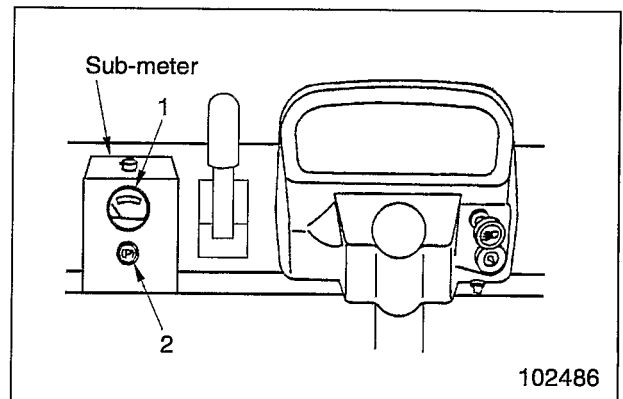

102486

## Major Components

### Electronic Control Unit (ECU)

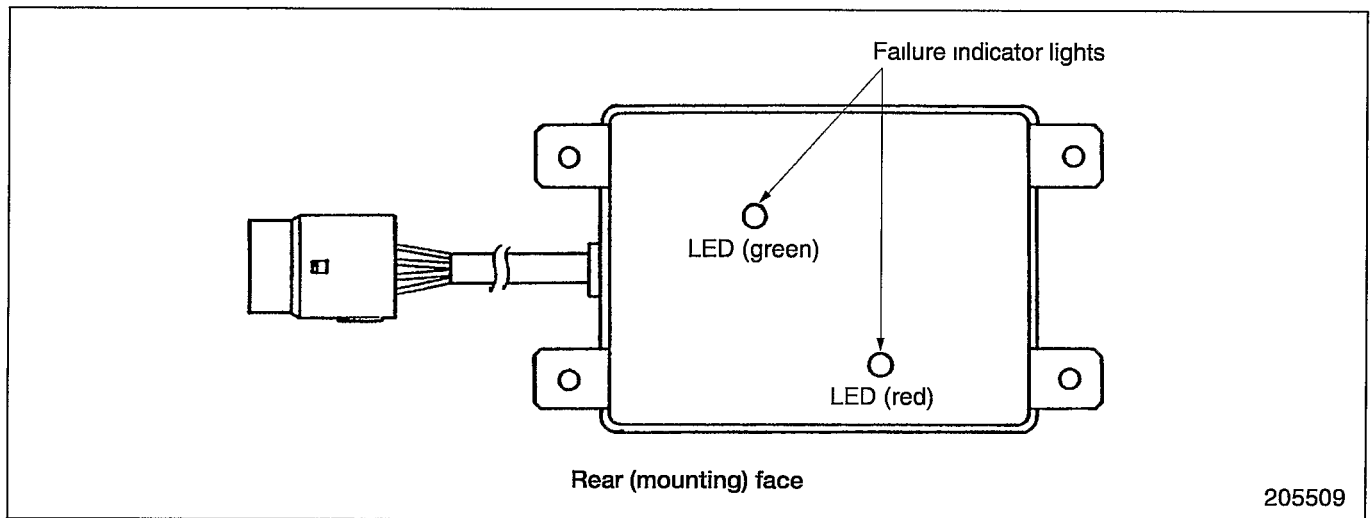

The Electronic Control Unit (ECU) has a built-in 1-chip microcomputer. This computer processes signals from the travel speed sensor for actuating the 2-speed automatic transmission.

The ECU has “self-diagnostic” failure indicator lights which come on when any problem occurs in the electrical system, thereby allowing the operator to locate the problem. It has the following fail-safe systems so that

failure of power, control circuit, or other components will not endanger the operator.

**NOTE**

The failure indicator lights are located on the rear (mounting) face of the ECU. This makes it necessary to remove the ECU from the truck to observe these lights.

### Fail-safe Systems

Failure	Function
Solenoid output signal circuit open	Turns OFF the power line and causes an indicator light to come on when the solenoid output signal circuit is open.
Travel speed sensor circuit open	Allows the truck to run at the present travel speed but causes an indicator light to come on.

### Failure Indicator Light Flashing Patterns

Failure	Flashing pattern
Travel speed sensor circuit open	
2-speed automatic transmission control circuit open	

204697

NOTE: The failure indicator lights come ON and go OFF as shown below:

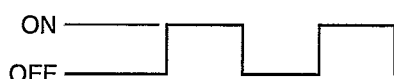

204668

**Starter Switch (Anti-restart Type)**

This switch has a built-in mechanical lockout. This lockout restrains the key from turning to  (START) position from | (ON) position (as when the engine is

running) to help prevent damage to the starter pinion or flywheel ring gear. The | (ON) position of the switch is for energizing the glow plugs.

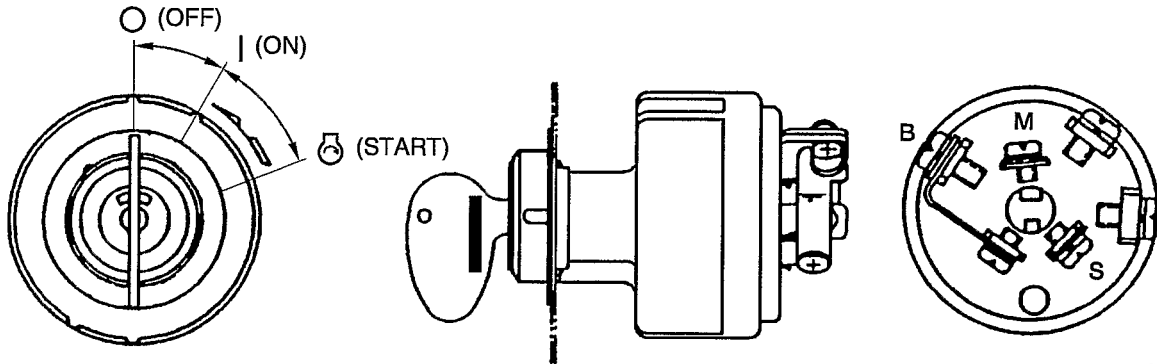

203561A

**Connection Chart**

Terminal	B	M	S
Component	Fuse box, batteries, alternator, glow plugs	Fuse box, engine stop control timer, glow plug timer and relay	Transmission shift lever, glow plug timer
○ (OFF)	○		
(ON)	○ —	○ —	
 (START)	○ —	○ —	○ —

**Lighting Switch**

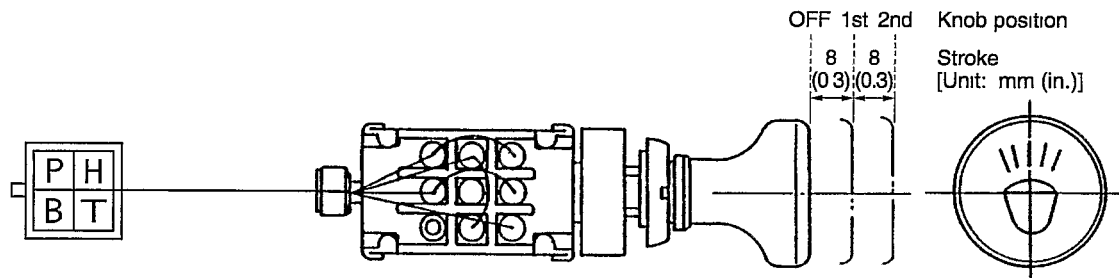

206481

**Connection Chart**

Terminal	B	T	H	P
Component	Batteries (fuses)	Tail lamps, license plate lamp (option), instrument panel lamp	Headlamps	Front combination lamps
○ (OFF)				
1st position	○ —	○ —		○ —
2nd position	○ —	○ —	○ —	○ —



Fuse Box

Symbol	Capacity	Circuit
A	10 A	Transmission shift lever
B	10 A	Instrument panel lamp, turn signals
C	10 A	Spare terminal
D	15 A	Lamps
E	10 A	Horn
F	10 A	Spare
G	10 A	Transmission controller, vacuum buzzer, stop lamps
H	10 A	Back-up lamps
J	15 A	Spare

101441F

Spare Terminals



The spare terminal cord extends from the fuse box in the console box. (Another spare terminal is in the chassis-side main harness.)

Color code	Lg (light green)
------------	------------------

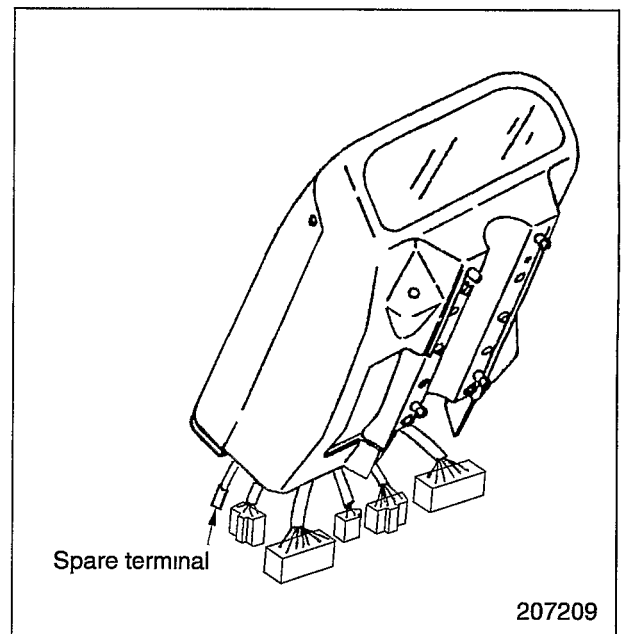
Removing the console box rear panel will permit you to gain access to this spare terminal which is taped to the harness protector.

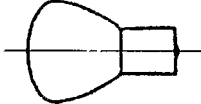
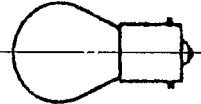
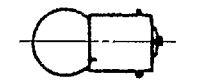
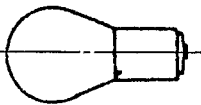
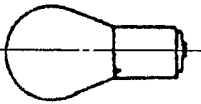
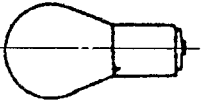
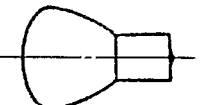
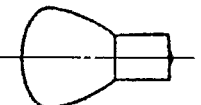
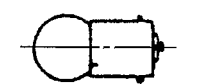
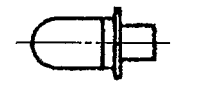

## Lamp Bulb Specifications

Item Type of lamp		Quantity of bulbs	Color of lens	Bulb		Remarks
				For 24V system	Schematic drawing	
Headlamps		2	Frosted	60W		60/60W (option)
Combination lamps (front)	Turn signal lamps	2	Amber	25W		Standard (mounted on overhead guard)
	Clearance lamps	2	Frosted	12W		
Combination lamps (rear)	Stop and tail lamps	2	Red	10W/25W		
	Turn signal lamps	2	Amber	25W		
	Back-up lamps	2	Frosted	25W		
Working lamps (front)		2	Frosted	60W		Option
Working lamps (rear)		2	Frosted	60W		Option
License plate lamps		1	Frosted	12W		Option
Instrument panel lamps		2	Frosted	3W		For combination meter
OK monitor indicator lamps		5	Frosted	3W		

## Suggestions for Removal and Installation

### Console Box

#### Removal

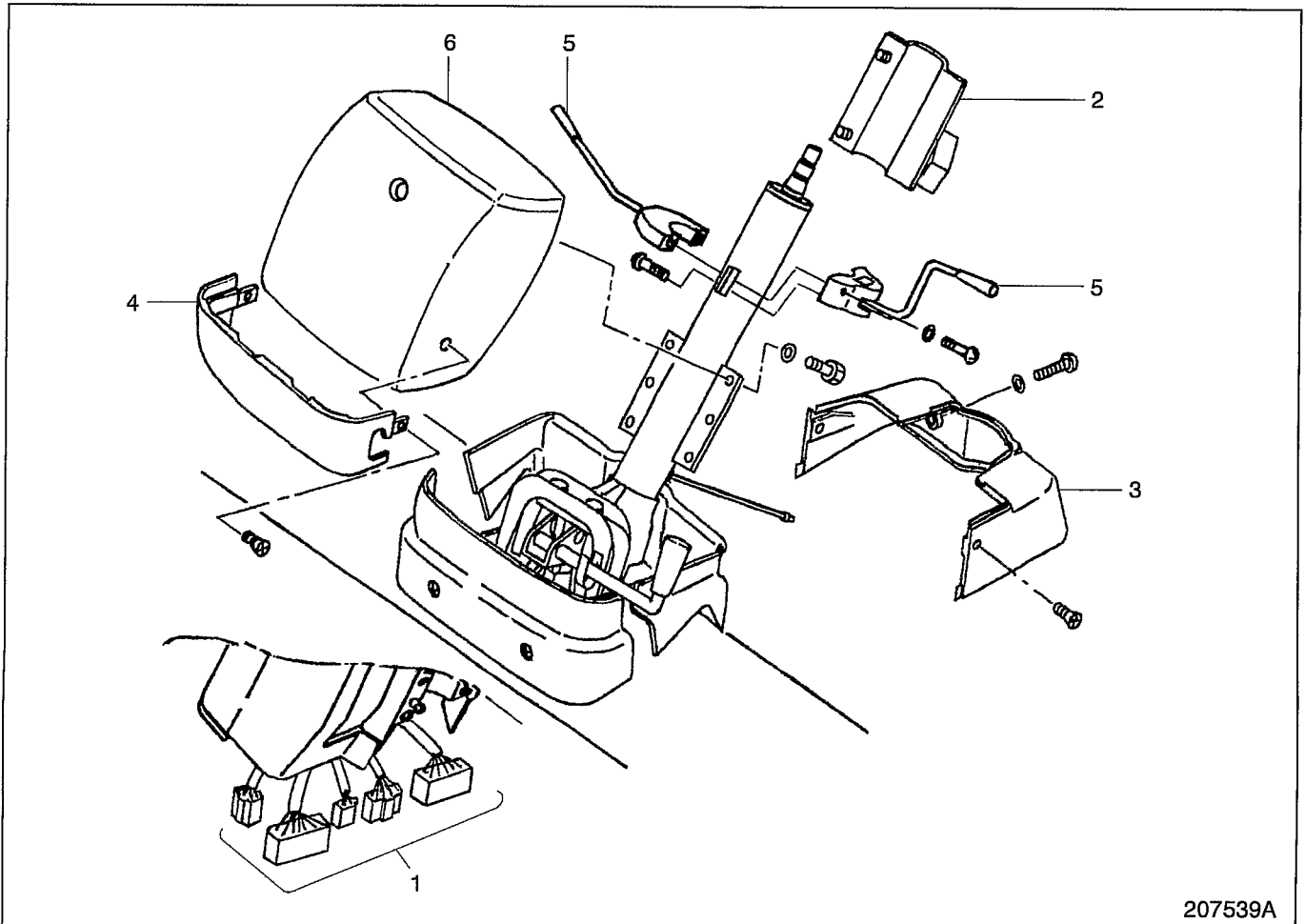

207539A

#### Start by:

- (a) Turn off the starter switch, and disconnect the negative (grounding) cable from the battery.
- (b) Remove nut and washer on steering wheel, and remove the steering wheel.

#### Sequence

1. Disconnect the electrical wires at connectors 1.
2. Remove screws on cover 2 using a flat-tip screwdriver, and remove the cover.
3. Remove screws on cover (U-RE) 3, and remove the cover.
4. Remove screws on cover (U-FR) 4, and remove the cover.
5. Disconnect the electrical wires at connectors, and remove transmission shift lever and turn signal lever 5.
6. Remove bolts on console box assembly 6, and remove the console box assembly.

#### Installation

To install, follow the reverse of removal sequence.

**BUY NOW**

**Then Instant Download  
the Complete Manual  
Thank you very much!**